



Scan this code to get the most updated manual.

INSTALLATION, OPERATION & MAINTENANCE MANUAL



MODELS:

**HD2P-9KMSC
9,000 LB CAPACITY 2 POST LIFT**

⚠ FOLLOW THIS MANUAL CAREFULLY TO ENSURE THE EQUIPMENT WILL FUNCTION CORRECTLY AND PROVIDE MANY YEARS OF DEPENDABLE SERVICE. FAILURE TO FOLLOW THESE INSTRUCTIONS AND SAFETY WARNINGS MAY RESULT IN PERSONAL INJURY OR PROPERTY DAMAGE. KEEP THIS MANUAL IN A SAFE DRY PLACE FOR FUTURE REFERENCE.



**Products May Be
Upgraded Without Notice
Please Visit**

WWW.TITANLIFTS.COM

**For The Latest Version Of
This Manual**

CONTENTS

1-SAFETY	1
1.1 INTRODUCTION.....	1
1.2 SAFETY INSTRUCTIONS FOR COMMISSIONING.....	1
1.3 SAFETY INSTRUCTIONS FOR OPERATION.....	1
1.4 SAFETY INSTRUCTIONS FOR MAINTENANCE	3
1.5 RISKS.....	3
2-DESCRIPTION	4
3-UNPACKING & SETUP	5
3.1 DELIVERY AND CHECK OF PACKAGES	5
3.2 LIFTING AND HANDLING.....	5
3.3 PREPARATION	5
4 SPECIFICATIONS	6
5-FLOOR REQUIREMENTS	6
5.1 SELECTING THE SITE AREA	6
5.2 FLOOR REQUIREMENTS	6
5.3 IMPORTANT CONCRETE AND ANCHORING INFORMATION	7
5.4 ANCHORING TIP SHEET	7
6-INSTALLATION INSTRUCTIONS	8
7-OPERATION INSTRUCTIONS	15
7.1 DEFECTS / MALFUNCTIONS.....	15
7.2 CONTROLS.....	15
7.3 OPERATION.....	16
8-MAINTENANCE	18
8.1 MAINTENANCE SCHEDULE	18
8.1.1 DAILY	18
8.1.2 WEEKLY	18
8.1.3 MONTHLY.....	19
8.1.4 BIMONTHLY.....	19
8.1.5 YEARLY	19
8.1.6 EVERY OTHER YEAR.....	19
8.2 MAINTENANCE BY OPERATOR	20
8.2.1 HYDRAULIC SYSTEM	20
8.2.2 GREASING POINTS.....	20
8.2.3 OPERATION AND WEAR CHECKS	21
8.2.4 LIFT STABILITY	21
8.3 CLEANING	21
9-TROUBLESHOOTING	22
10-OWNER/EMPLOYER RESPONSIBILITIES	23
11-DIAGRAMS (FIG. 1-11)	24
FIG. 1 - EXPLODED PARTS VIEW	24
FIG. 2 - ADAPTERS	26
FIG. 3 - CARRIAGE	27
FIG. 4-1 - CABLE	28
FIG. 4-2 - CROSSBEAM	28
FIG. 5 - SAFETY LOCKS	29
FIG. 6 - HOSES/POWER UNIT	30
FIG. 7 - CABLES / PULLEYS	31
FIG. 8 - POWER UNIT	32
FIG. 9 - HYDRAULICS	33
FIG. 10 - ELECTRICAL	34
FIG. 11 - DIMENSIONS	35



TITAN MARKETING, LLC

PO Box 7069 Greenwood, IN 46142
1.888.908-4826 FAX (317) 215.2770
www.titanlifts.com

To Our Valued Customers:

Thank you for purchasing a Titan Lifts® product. We hope this high quality equipment provides you with years of dependable service.

It is unfortunate that rare situations may occur with the products you purchase from Titan Lifts®. We value your business as well as the trust you have and need to maintain your relationship with us. Titan Lifts® carries liability coverage that may protect our customers if a situation does occur. However, as in all accidents there must be proof of liability for a claim to be made. Our insurance company requires the following procedures be observed in order to consider a claim:

- A. The claimant must contact the Titan Lifts® distributor immediately with the facts of the situation.
- B. If any equipment is damaged, including vehicles or shop equipment, Titan Lifts® must be given the opportunity to send an impartial representative to the site for proper assessment of the situation.
- C. The Vehicle cannot be moved until either an impartial representative has reviewed the accident or clear and precise pictures are taken that reflect all the pertinent information for an impartial representative to be able to access the information from a distance. Titan Lifts® or its representatives must approve the pictures before anything can be moved.
- D. If any potential liability is determined on behalf of Titan Lifts®, two estimates must be submitted for damages to be reimbursed.

It is imperative that the claimant complies with these procedures, because without proper assessment of the situation a claim will be denied.

ARBITRATION NOTICE

The installation or use of this equipment shall constitute an acknowledgement that the user agrees to resolve any and all disputes or claims of any kind whatsoever, which relate in any way to the equipment, by way of binding arbitration, not litigation. No suit or legal action may be filed in any state or federal court. Any arbitration shall be governed by the Federal Arbitration Act, and administered by the American Mediation Association, Indianapolis Indiana. The maximum amount that an arbitrator may award and all damages shall not exceed the retail value of this equipment.

WARRANTY NOTICE

This equipment must be assembled and used in the manner according to the documentation provided to be covered by warranty.

Damaged or missing components must be reported within 72 hours of receipt to your freight carrier and to the distributor. Claims must be filed to cover cost.

If you have any questions or if we can be of any further assistance, please don't hesitate to contact a Titan Lifts® representative at 1-888-908-4826. Thank you for the opportunity to continue to serve your lift equipment needs.

INSTRUCTIONS

1-SAFETY

1.1 INTRODUCTION

 **WARNING:** READ ENTIRE MANUAL AND COMPLY WITH ALL SAFETY AND SERVICE PRECAUTIONS. DEATH, PERSONAL INJURY AND / OR PROPERTY DAMAGE MAY OCCUR IF INSTRUCTIONS ARE NOT FOLLOWED CAREFULLY.

Personal injury and property damage incurred due to non-compliance with these safety instructions are not covered by the product liability regulations.

SYMBOLS

 **FAILURE TO COMPLY WITH INSTRUCTIONS COULD RESULT IN PERSONAL INJURY.**

 **FAILURE TO COMPLY WITH INSTRUCTIONS COULD RESULT IN PROPERTY DAMAGE.**

 **IMPORTANT INFORMATION**

1.2 SAFETY INSTRUCTIONS FOR COMMISSIONING

- The lift may be installed and commissioned by authorized service personnel only.
- The standard lift version may not be installed and commissioned in the vicinity of explosives or flammable liquids, outdoors or in moist rooms (e.g. car wash).

1.3 SAFETY INSTRUCTIONS FOR OPERATION

- Read this entire manual.
- Load should not exceed rated capacity for this lift –9,0000 lbs. (2,250 lbs per lift arm)
- Only trained authorized personnel over the age of 18 years should operate the lift.
- Indoor use recommended.
- Always lift the vehicle using all four arms.
- Never use the lift to raise one end or one side of vehicle.

- Maintain a safe working environment. The work area should be clean, dry, clutter free, and sufficiently lit.
- Vehicle doors should be closed during the raising and lowering cycles.
- Closely watch the vehicle and lift during the raising and lowering cycles.
- Do not operate the lift in explosive atmospheres, such as in the presence of flammable liquids, gases, or dust. Power equipment can create sparks which may ignite flammables.
- Keep hands, tools, and other extremities from under carriage and moving parts.
- Never operate this lift with someone on it.
- Do not allow anyone on the lift or inside a raised vehicle.
- Keep children and bystanders away from work area. Do not let children operate or play on lift.
- Wear proper safety attire. Do not wear loose fitting clothing while operating lift. Long hair, jewelry and sleeves should be secured.
- Never leave the lift unattended while under a load.
- Do not operate this lift if under the influence of drugs, alcohol, or medication. Operator must be alert at all times when using heavy lift equipment.
- Comply with all applicable accident prevention regulations.
- Only use the vehicle manufacturer's recommended lifting points.
- After positioning the vehicle, apply the parking brake.
- Use caution when removing or installing heavy vehicle components which may result in center-of-gravity displacement.
- Use this lift only for the work it is intended. Do not use this product for an application for which it was not designed. Misuse can lead to personal injury and/or property damage.

 **WARNING:** Prior to completely raising the vehicle, raise the vehicle 6" off the ground and check the adapter pads for solid contact by performing the "BUMPER TEST". Walk around the back of the vehicle and push up and down on the bumper. The vehicle will rock, but should not at any time lose contact with the pads. If the vehicle is bouncing off the pads or feels at all unstable, you should lower it back to the ground and reposition the pads to balance the load. Repeat this process until the vehicle is completely stable.

 **WARNING:** Use this lift only in well ventilated areas. Carbon monoxide exhausted from running vehicle engines is a colorless, odorless fume that, if inhaled, can cause serious personal injury or death.

 **WARNING:** People with pacemakers should consult their physician(s) before using this product. Operation of electrical equipment in close proximity to a heart pacemaker could cause interference or failure of the pacemaker.

 **WARNING:** This product contains or produces a chemical known to the State of California to cause cancer and birth defects (or other reproductive harm). (California Health & Safety Code 25249.5 et seq.)

1.4 SAFETY INSTRUCTIONS FOR MAINTENANCE

- Maintenance or repair work should be done by authorized service personnel only.
- Work on the electrical equipment should be done by certified licensed electricians only.
- Ensure that ecologically harmful substances are disposed of in accordance with the appropriate regulations.
- To prevent the risk of damage, do not use high pressure / steam jet cleaners or caustic cleaning agents.
- Do not replace or override the safety devices.

1.5 RISKS



WARNING: Risks the personnel could encounter, due to an improper use of the lift, are described in this section.

CRUSHING RISK

During lowering of runways and vehicles, personnel must not be within the area covered by the lowering trajectory. The operator must be sure no one is in danger before operating the lift. Stay clear of the lift when lowering or raising vehicles. Keep hands and feet away from moving parts and especially points that could pinch. Keep your feet clear of the lift when raising and lowering vehicles.

BUMPING RISK

When the lift is stopped at relatively low working height, the risk of bumping against projecting parts increases. Always be aware of your surroundings and avoid bumping your head or body on the lift or the vehicle.

RISK OF THE VEHICLE FALLING FROM THE LIFT

Risk of the vehicle falling from the lift is increased: when the vehicle is improperly placed on the platforms, when the vehicle's weight or physical dimensions exceed the rated capacity of the lift, or when there is excessive movement of the vehicle while on the lift. If vehicle appears to begin falling, exit the area as quickly as possible to avoid injury. Always position vehicle with the center of gravity midway between the adapters. Adding or removing parts of a vehicle on the lift will alter the weight displacement on the lift. Therefore, use of auxiliary safety stands in the front and back of the vehicle is recommended. Never override the manufactured lift controls. Always use height adapter pads when possible to ensure proper contact. Only authorized personnel should be allowed in the lift area and the lift should only be operated by authorized and trained personnel. Adding or removing parts of a vehicle on the lift will alter the weight displacement on the lift.

2-DESCRIPTION

HD2P-9KMSC- Heavy Duty, 2-post, 9000lb capacity, Master Series, Clear-floor lift with Asymmetric arms

This lift is a 9,000 lb. capacity, 2-Post Lift. The safety latch system is very similar to an extension ladder. The safety latch is manually released by a single lever and the spring-loaded locks engage into place as the carriages are raised. The safety locks must be manually disengaged for the lift to descend. If the user lets go of the manual release handle, the safety latch will re-engage on the next lock latch below. Due to the "Direct Drive" hydraulic system, this lift does not have the typical chain-over-roller style cylinder. Each cylinder is inverted, positioned through the center of the carriages, and a steel collar that's welded to the cylinder casing will contact the lifting plate on the carriage. The cylinders are driven by a hydraulic pump capable of providing 3,000 psi.

Please read the Safety Procedures and operation instructions in this manual before operating the lift. Proper installation is very important. To minimize the chance of making an error in installation, we recommend that this equipment be installed by a professional equipment installer that is well versed in these types of lifts. Check with building owner and/or architect's building plans when applicable. The lift should be located on a level floor with 4" 3000 psi concrete sufficiently cured, for at least 30 days.

This is a vehicle lift installation / operation manual and no attempt is made or implied herein to instruct the user in lifting methods particular to an individual application. Rather, the contents of this manual are intended as a basis for operation and maintenance of the unit as it stands alone or as it is intended and anticipated to be used in conjunction with other equipment.

Proper application of the equipment described herein is limited to the parameters detailed in the specifications and the uses set forth in the descriptive passages. Any other proposed application of this equipment should be documented and submitted in writing to the factory for examination. The user assumes full responsibility for any equipment damage, personal injury, or alteration of the equipment described in this manual or any subsequent damages.

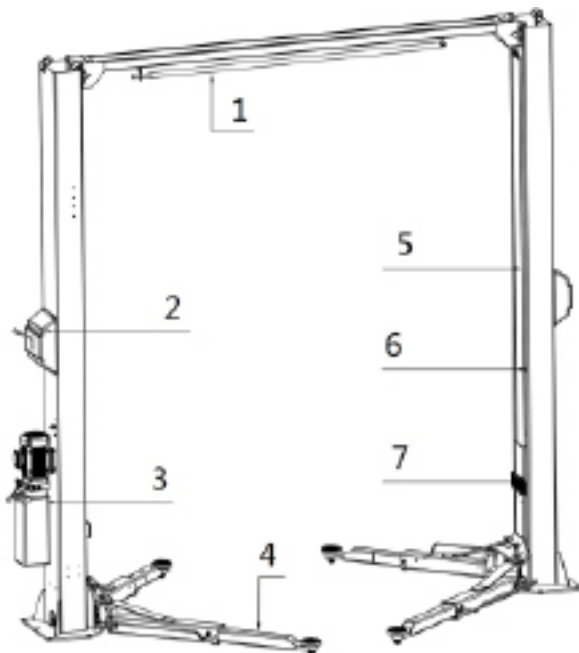

1. Overhead crossbeam
2. Mechanical safety latch
3. Hydraulic power unit
4. Lifting arm
5. Post
6. Hydraulic cylinder
7. Carriage

3-UNPACKING & SETUP

Only skilled personnel who are familiar with the lift and this manual shall be allowed to carry out, lifting, handling, transport and unpacking operations.

3.1 DELIVERY AND CHECK OF PACKAGES

When the lift is delivered, carefully unpack the lift making sure all the parts have been included. Check for possible damages due to transport and storage; verify that what is specified in the confirmation of order is included. In case of damage in transit, the customer must immediately inform the carrier of the problem.

Remove the lift and all parts from delivery pallet and place on a clean, solid, flat surface. Packages must be opened paying attention not to cause damage to people (keep a safe distance when opening straps) and parts of the lift (be careful the objects do not drop from the package when opening.)

3.2 LIFTING AND HANDLING

When loading/unloading or transporting the equipment to the site, be sure to use suitable loading (e.g. cranes, trucks) and hoisting means. Be sure to hoist and transport the components securely so that they cannot drop, taking into consideration the package's size, weight, center of gravity, and its fragile parts.



LIFT AND HANDLE ONLY ONE PACKAGE AT A TIME

3.3 PREPARATION

Professional installation is required. The following tools and equipment are needed:

1. ISO-32 or AW-32 hydraulic oil (2.5 Gallons)
2. Chalk line and Tape Measure
3. Rotary Hammer Drill with 3/4" Drill Bit. Core Drill Rebar Cutter recommended
4. 4' Level
5. Sockets and Open Wrench set, metric & standard (1-1/8" for 3/4" Anchors)
6. Pliers
7. Torque Wrench
8. Metric allen wrench set

4 SPECIFICATIONS

Model	Description	Capacity	Lifting Time	Overall Height*	Overall Width	Between Posts
HD2P-9KMSC	Clear Floor/ Asymmetric	9,000 lbs	50-60 sec.	140 1/2"	142"	111 1/2"
			Drive-Thru	Low Pad Height	Lifting Height	Power Unit
			100 3/4"	3 3/4"	74 1/4" - 81 3/4"	220V/1Ph/60Hz

***CYLINDERS WILL EXTEND 7" THROUGH THE TOP PLATES WHEN LIFT IS RAISED TO MAX HEIGHT.**

Due to minor variances in the manufacturing process, dimensions in this manual may vary slightly from the finished product.

5-FLOOR REQUIREMENTS

5.1 SELECTING THE SITE AREA

1. Make sure that adequate space and height is available.
2. Check for ceiling clearance (lifting height plus vehicle height).
3. Check for clearance in front and rear of vehicle on lift.
4. Check for overhead garage door clearance.

5.2 FLOOR REQUIREMENTS

Do not use the lift on any asphalt surface. Make sure the lift is used on a dry, oil/grease free, flat level CONCRETE surface capable of supporting the weight of the lift, the vehicle being lifted, and any additional tools and equipment. The concrete floor surface should have a minimum thickness of 4". The concrete must have a minimum strength of 3,000 PSI, and should be aged at least 30 days prior to use. Do not use the lift on concrete expansion seams or on cracked, defective concrete.

 **WARNING: SPECIFICATIONS OF CONCRETE MUST BE ADHERED TO. FAILURE TO DO SO COULD CAUSE LIFT FAILURE RESULTING IN PERSONAL INJURY OR DEATH. THE FLOOR SHOULD BE A REINFORCED CONCRETE SLAB NOT LESS THAN 4" (101.6MM) THICK WITH THE COMPRESSIVE STRENGTH OF THE CONCRETE NO LESS THAN 3,000 PSI.**

 **DANGER: FOR CORRECT INSTALLATION OF THE LIFT, THE FLOOR MUST BE FLAT AND LEVEL. CHECK WITH STRAIGHT EDGE AND LEVEL. IF A FLOOR IS OF QUESTIONABLE SLOPE, CONSIDER A SURVEY OF THE SITE AND/OR THE POSSIBILITY OF POURING A NEW LEVEL CONCRETE SLAB.**

 **IMPORTANT: NEW CONCRETE MUST BE ADEQUATELY CURED AT LEAST 30 DAYS MINIMUM. NO LIABILITY FOR ANY DAMAGES WILL BE ACCEPTED SHOULD YOU INSTALL THE LIFT ON AN UNSUITABLE FLOOR.**

5.3 IMPORTANT CONCRETE AND ANCHORING INFORMATION

1. Concrete shall have compression strength of at least 3,000 PSI and a minimum thickness of 4". Measure the length of the supplied anchor bolts in order to achieve a minimum anchor embedment of 3-1/4". If the top of the anchor exceeds 2" above the floor grade, you DO NOT have enough embedment.
2. Before drilling 3/4" dia. Holes in concrete floor using holes in column base plate as guide, make sure the hole distance from the edge is not less than 6". Hole to hole spacing should not be less than 6 1/2 in any direction. Concrete thickness should be a minimum of 4"
3.  **DANGER: DO NOT** Install on asphalt or other similar unstable surface. Columns are supported only by anchoring in floor.
4. Shim each column base until each column is plumb. If one column has to be elevated to match the plane of the other column, full size base shim plates should be used. Torque anchors to 85 ft-lbs. Shim thickness MUST NOT exceed 1/2". Adjust the column extensions plumb.
5. If anchors do not tighten to 85 ft-lbs. installation torque, replace concrete under each column base with a 4' x 4' x 12" thick 3,000 PSI minimum concrete pad keyed under and flush with the top of existing floor. Let concrete cure at least 30 days before installing lifts and anchors.

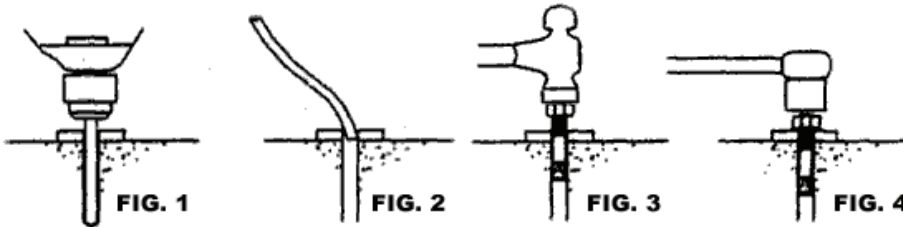

**DO NOT USE AN IMPACT
WRENCH TO TIGHTEN
ANCHORS!**

5.4 ANCHORING TIP SHEET

1. Use a concrete hammer drill with a carbide tip, solid drill bit the same diameter as the anchor, 3/4". (.775 to .787 inches diameter). **Do not use excessively worn bits or bits which have been incorrectly sharpened.**
2. Keep the drill perpendicular to the concrete while drilling.
3. Let the drill do the work. Do not apply excessive pressure. Lift the drill up and down occasionally to remove residue to reduce binding.
4. Drill the hole for anchor bolt completely through the concrete. If an error is made during the installation of these anchors, this will allow for the anchor bolt to be driven down into the ground, so that a new anchor may be installed in place (fig.1).
5. **Be sure to clean all dust from hole.** (fig. 2).
6. Place a flat washer and hex nut over threaded end of anchor, leaving approximately 1/4 inch of thread exposed above the nut (fig. 3). Carefully tap anchor into the concrete until nut and flat washer are against base plate. Be sure to only tap the top of the anchor and not the nut. This could cause damage to the threads of the anchor.
7. Tighten the nut (fig. 4) to **85 ft-lbs** of torque.

6-INSTALLATION INSTRUCTIONS

PLEASE NOTE THAT ALL DIMENSIONS GIVEN ARE FOR REFERENCE ONLY. FINAL DIMENSIONS MAY VARY SLIGHTLY. LIFT COLUMNS MUST BE PLUMB AND SQUARE REGARDLESS OF FINAL DIMENSIONS.

PLEASE THOROUGHLY READ THESE INSTRUCTIONS BEFORE BEGINNING INSTALLATION OR OPERATION OF THE LIFT.

1. Check ceiling height to confirm the lift can be set up in your area, then place the lift near the intended installation location. Clean any debris from the floor and check for any cracks or expansion joints that are in this area. Locate any floor drains and know which direction they are flowing. **NOTE:** Concrete must be at least 4" thick, have a compression strength of at least 3000psi, and be cured at least 30 days, prior to installing any concrete wedge anchors.
2. Remove the shipping bands, packing materials and the power unit from the lift. Carefully remove the parts from inside the column. Unbolt the column from the shipping brackets and stand the columns up in the area that the lift will be installed. Determine which column the power unit will be mounted on and position it on the side that you prefer. **NOTE:** The power unit column can be set on either side.
3. Place a chalk line on the ground and position the baseplates on the line to where the measurement between the inside of the columns is approximately 111.5". The concrete anchors must be a minimum of 8" away from any cracks, expansion joints, floor drains, and the edge of concrete. Be sure to check this when finalizing the placement of the lift.
4. Install the lock assemblies on each column. Be sure that the bracket that accepts the lock release handle is installed on the power unit side.
5. Using a 3/4" diameter concrete drill bit, begin drilling the holes for the anchors for ONE COLUMN ONLY, installing anchors as you go. Be sure that you are drilling all the way through the concrete slab when possible. We recommend using a vacuum during and after drilling to help remove all concrete dust from the holes. **Note:** Remember to place washer and nut on the threads, leaving approximately 1/4" of the anchor stud exposed above the nut. Use an appropriately sized hammer to drive anchor bolts flush with the baseplate.
6. Tighten anchor bolts down so that the baseplate is flush on the ground. You don't need to torque them down just yet; this step is just to determine how plumb the column is on the ground. Using a 4' level, check the plumb on the column in both directions, holding the level up about $\frac{3}{4}$ of the way up the column. If the column isn't plumb, you can place the provided shims around the anchor bolts to achieve a perfect vertical plumb on the column in both directions. (Shim thickness should not exceed 1/2"). Once the column is plumb, you are now ready to use your torque wrench to torque the nuts down on the anchor bolts. These will need to be torqued to 85ft/lbs. **Note: Do not use impact wrench.**

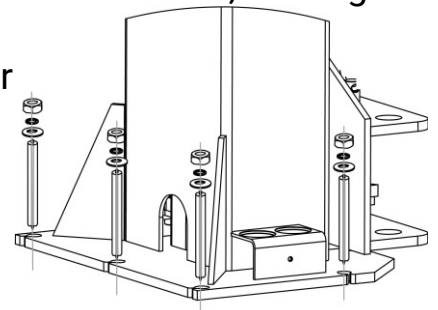

7. Locate the overhead safety shut-off switch and safety shut-off bar, then attach them to the brackets welded to the underside of the overhead crossbeam. Now that the overhead crossbeam assembly is together, it's a good idea to re-measure the distance between the columns so that they are the proper distance apart (111.5") before installing the overhead crossbeam. You will want to make sure that the overhead shutoff switch is mounted on the same side of the lift as the power unit. **NOTE:** There are tabs mounted to the ends of the overhead crossbeam that will allow you to rest the crossbeam on the front edges of the columns. This allows you to have both hands free to align the mounting holes and install the four (4) bolts that secure the crossbeam to the columns.

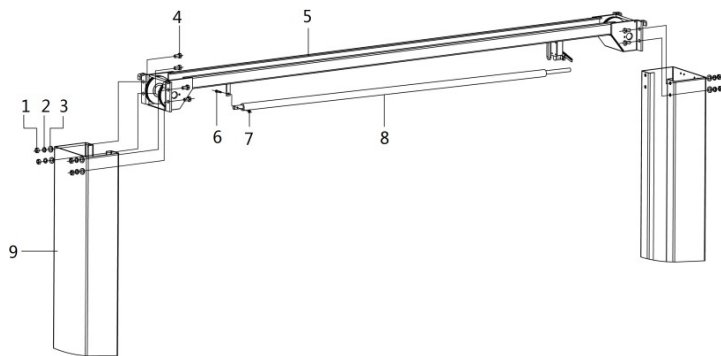

- | |
|---|
| 1. Hex nut M14 |
| 2. Flat washer M14 |
| 3. Spring washer M14 |
| 4. Hex head full swivel screw M14*30 |
| 5. Crossbeam |
| 6. Hex socket cylinder head screw M6*30 |
| 7. Hex nut M6 |
| 8. Protective rod |
| 9. Extending post |

8. Locate the (2) safety lock release pulley and bracket assemblies and install one at the top of each column. There are 2 mounting holes at the top of the column and you can use the supplied bolts and locking nuts to secure them in place.

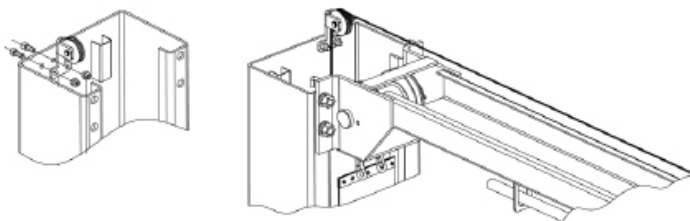

9. Route the long hydraulic hose from the offside column, through the hose guides in the crossbeam, and down through the hose guides on the inside of the power unit column. There is also a shorter hydraulic hose that's pre-installed inside the power unit column that goes from the cylinder, upward to a hole inside the column where the longer hose will end.
- Locate the hydraulic Tee-fitting inside the parts box and remove the nut from the Tee-fitting.
 - Loosely thread both ends of the hoses onto the top and bottom of the Hydraulic T-fitting,
 - Insert the male end through the column, and replace the nut on the outside of the column and tighten in place.
 - Finish tightening both hose ends to each side of the Tee-fitting.

! WARNING: BE SURE THE HOSE WILL BE CLEAR OF ANY MOVING PARTS INSIDE THE COLUMNS.

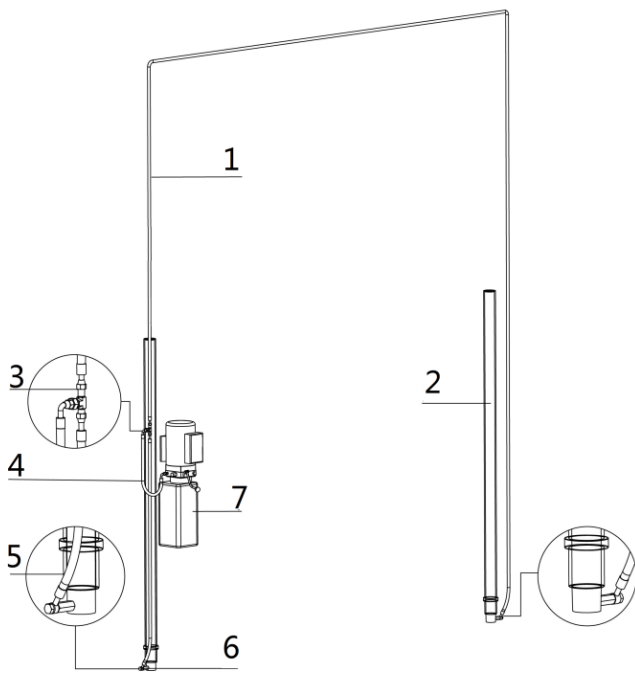

- 1.Oil hose A
- 2.Hydraulic cylinder
- 3.Three way connector
- 4.Oil hose B
- 5.Oil hose C
- 6.Composite connector
- 7.Power unit

- 1. Steel cable A
- 2. Steel cable B

10. At this point, you are now ready to route the equalizing cables. First, it's best to look down into the carriage and make sure that the cable is routed around the pulley at the bottom of the column. **NOTE:** There is a window in the middle of the columns that allow access to one end of the cable if needed. Route the other end of the cables around the pulleys at the top of the columns, through the overhead crossbeam, around the pulleys at the top of the opposite side column, then downward placing the cable stud through the mounting hole at the top of the carriage. Secure it with a washer and a nut. For the time being, only thread the nut up till its flush with the end of the stud.

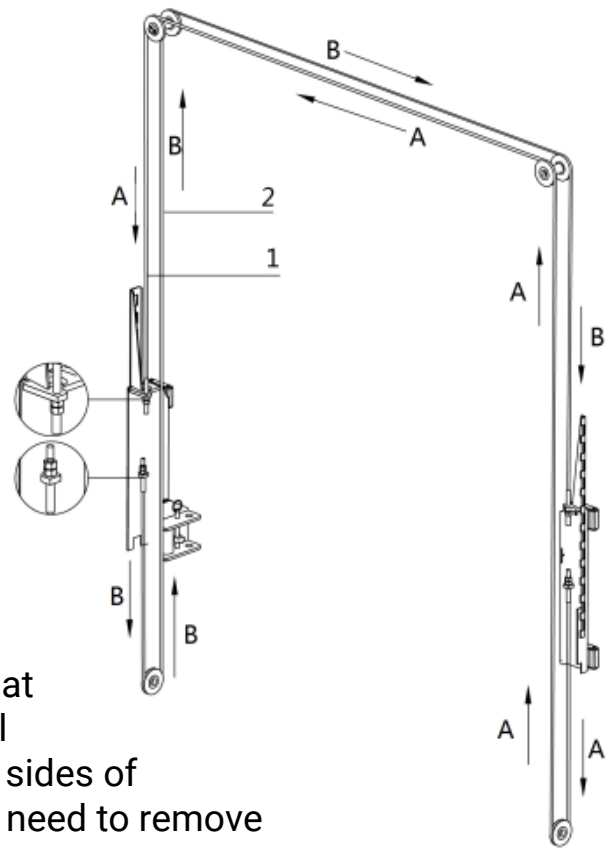

11. Route the safety release cable around the pulleys that are mounted at the top of the column. The cable will go through the crossbeam, about halfway down the sides of the columns, and around the pulleys below. You will need to remove the pulley brackets to allow the cable to pass through the column. As a reference, the safety release cable pulley on the power unit side is above the lock latch and the safety release cable pulley on the offside is below the lock latch. Run the ends of the cable up through each mounting tab and secure with the provided nuts. Tightening the nuts on both sides will take the slack out of the safety release cable. This will allow the lock latches to fully disengage when the safety release lever is pulled down.

locking device on power side post

locking device on the secondary post

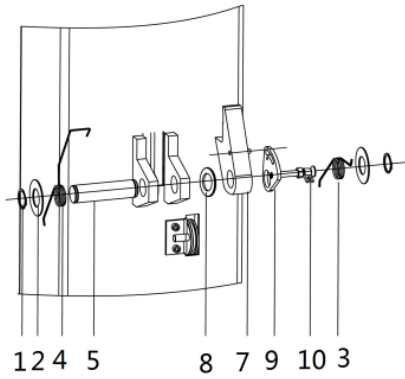
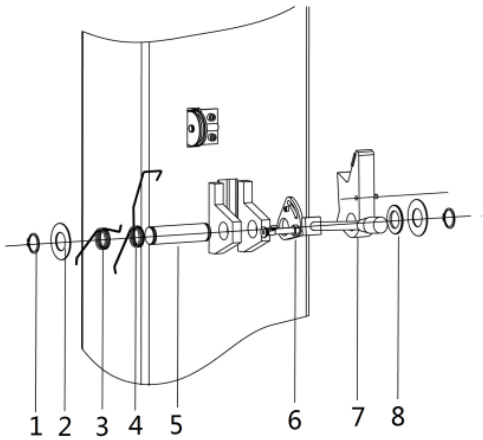

- 1.circlip
- 2.washer
- 3.spring 1
- 4.spring 2
- 5.shaft
- 6.handle
- 7.hook
- 8.nylon spacer
- 9.release plate
- 10.cable installation fitting

12. You are now ready to plumb the second column. With the column baseplate still on the chalk line, place the 4' level about $\frac{3}{4}$ of the way up the column and check the plumb on the backside of the column. Move the column closer or farther away from the first column until the level bubble is perfectly centered in the marks. Once plumbed, measure diagonally from the edge of one column (not baseplate) to the opposite edge of the other column, for each side. This measurement should be the same if the columns are perfectly squared to each other. Once these two steps are confirmed, you are ready to drill the holes for the anchors. Refer to Step 5 for anchoring instructions.

13. Tighten anchor bolts down so that the baseplate is flush on the ground. You don't need to torque them down just yet; this step is just to determine how plumb the column is on the ground. Since you have already set the plumb in/out from the other column, you only need to plumb the column in the front/back direction. If the column isn't plumb, you can place the provided shims around the anchor bolts as necessary. (Shim thickness should not exceed 1/2"). Once the column is plumb in both directions, you are now ready to use your torque wrench to torque the nuts down on the anchor bolts. These will need to be torqued to 85ft/lbs. **Note: Do not use impact wrench.**

14. Mount the power unit to the column using the supplied carriage bolts and nuts. Be sure that the head of the bolts are on the inside of the column. To ease with installation, we have slotted 2 of the mounting holes on the column so that you can put (2) bolts on the power-unit mounting plate and set the power-unit into place so that it's resting on the bolts while you are able to get the other (2) bolts installed. Once the power-unit is secure, install the short hose that connects the power unit to the fitting that is coming out of the column, then fill the power-unit reservoir with 2.5 gallons of AW-32 hydraulic oil.

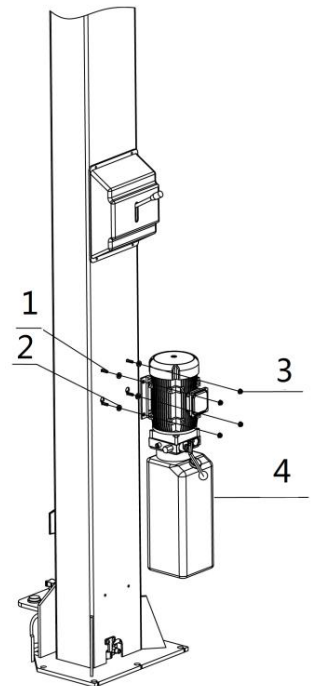

- 1.Hex head flange screw M8x30
- 2.Anti-vibration pad
- 3.Hex head flange nut M8
- 4.Hydraulic power unit

15. Next, you will want to tighten the nuts on the ends of the equalizing cable that are running downward into the top of the carriage. Tighten them to where you have just enough thread exposed to be able to put the jam-nut on after final adjustments. This is a good starting point for your equalization cables. **NOTE:** The equalizing cables are used to synchronize the lock latches to ensure that they are engaging simultaneously when operating the lift.

16. Place the Truck Adapter Holders on each column using the supplied hardware. These are a convenient way to store the Truck Adapters while they aren't in use.

- 1.Height adapter
- 2.Holder
- 3.Hex socket button head screw M8x12

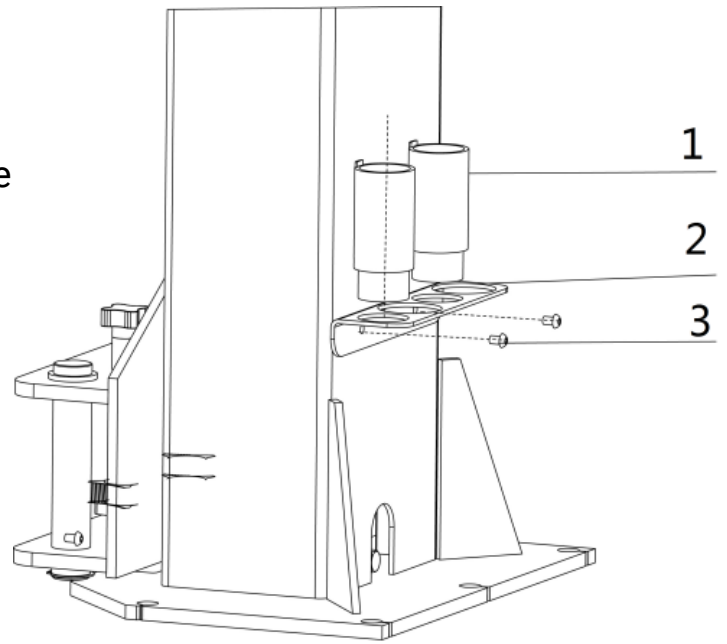

- 1.Holder
- 2.Release cable
- 3.Safety hook
- 4.Release handle

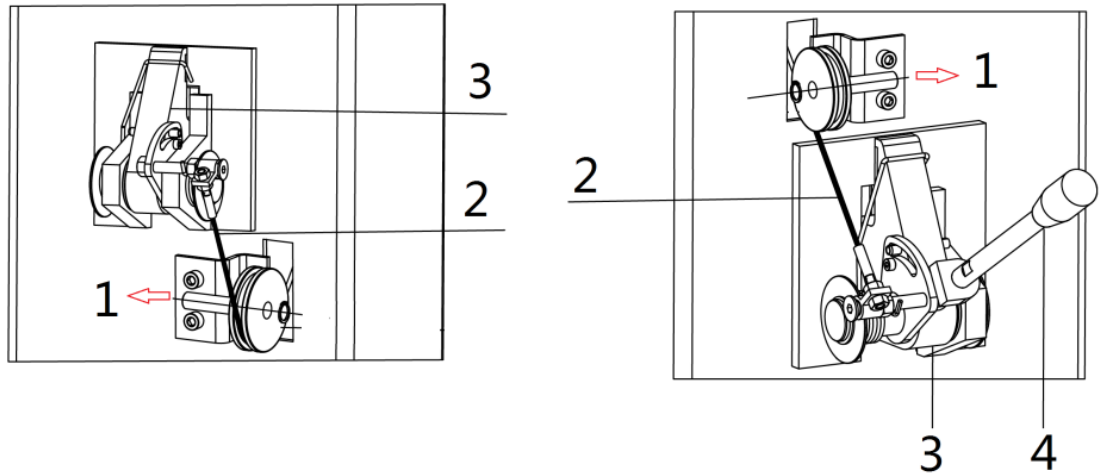

17. Apply a light coat of grease on the (4) Arm Pins and install the Lifting Arms into the Carriages. **NOTE:** The shorter, 3-stage arms will need to be placed under the front of the vehicle when in use. The longer arms are to be used under the back of the vehicle. Now that the arms are installed in the carriages, check for proper engagement of the arm restraint locks. The teeth on the Arm Restraint Pins should be fully engaged in the gear on the arm. Once the arms are installed, you can now install the Toe Guards on the outsides of the arms and drop your Rubber Pad Mounts into the ends of the arms. Notice that the end of the arm is "keyed" so be sure to align that with the notch in the Pad Mount Sleeve so that the entire assembly sits flush in the arm.

18. Install the secondary limit switch inside the column.

This limit switch is designed to interrupt the signal from the push button to keep from maxing out the cylinders. The wiring for both limit switches (Overhead Limit and Carriage Limit switch) can be routed within the hose guides and exits the column through a hole close to the Hydraulic T-fitting. You will want to remove the front panel from the junction box on Power-Unit motor and route the (2) cables into it. You will need to strip back some of the insulation on both cables to expose a total of (4) wires.

1. Max height limit switch
2. Cross socket flat head screw M 5x10
3. Cross socket flat head screw M 5x10
4. Wire

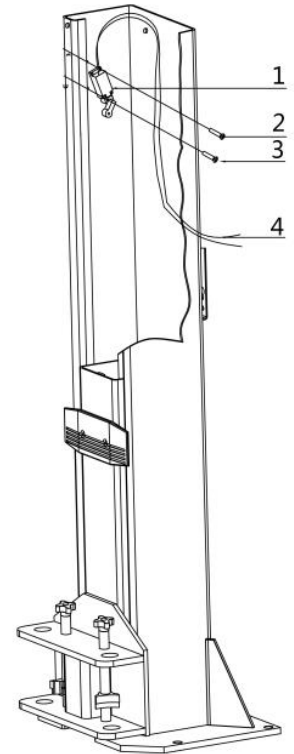

- A. Connect (2) of these wires together, leaving only (2) wires exposed.
- B. Remove (1) of the wires that runs from the Power Unit Control Button to the Contactor Relay.
- C. Attach (1) of your wires that's coming from the limit switches to the contactor.
- D. Attach the remaining wire to the push button.

1. Limit switch
2. Hex socket screw M4 x 25
3. Wire

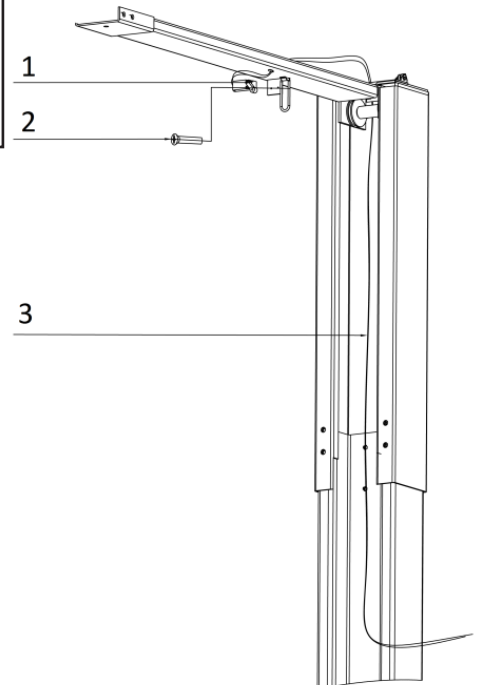

NOTE: If you have done this properly, when you trip the Carriage Limit Switch or the Overhead Limit Switch, the Power Unit Control Button won't be able to send power to the Motor.

19. It is required that a licensed Electrician make any connections coming from the main breaker to the Power-unit to prevent any accidental shorting or damage to the motor. The motor runs on 220V Single phase and it **MUST** be wired on its own circuit. Be sure to use 10/2 wire so that it can support a 30-amp circuit. NOTE: As a suggestion, we recommend installing a quick disconnect near the Power-unit in the event that power needs to be disconnected quickly.

! WARNING: THE WIRING MUST COMPLY WITH LOCAL CODE. HAVE A CERTIFIED LICENSED ELECTRICIAN MAKE THE ELECTRICAL HOOK-UP TO THE POWER UNIT. PROTECT EACH CIRCUIT WITH TIME DELAY FUSE OR CIRCUIT BREAKER; 208V-230V SINGLE PHASE. 50HZ/60HZ 30 AMP.

20. Before operating the lift, its best to do a quick check on all the installed hardware, hydraulic fittings, and hose ends. This is also a great time to lubricate moving components such as, pulleys, pins, as well as the (4) inside corners of both columns. This will allow the nylon slide blocks attached to the carriages to travel smoothly inside the columns when under load.

YOU ARE NOW READY TO OPERATE YOUR LIFT.

21. Press the Power-Unit Control Button to activate the pump and raise the carriages a few feet from the ground, stopping before the first lock engages. This lift uses a direct drive cylinder lifting system. The only way to properly bleed air from the system is to open the bleeder bolt that are located on the top of each cylinder.
- A. Loosen the bleeder bolt slowly to bleed air from each cylinder and tighten the bolt once fluid seeps out of the hole. You might also see the cylinders/carriages drop down a bit as the air escapes- This is a good sign.
 - B. After bleeding both cylinders, raise both carriages all the way to the top and continue to hold the button for 1-second after the cylinder is at max height.
 - C. Check all hoses and fittings for leaks then pull down and hold the Lock Release Lever, depress the Lowering Handle on the Power-Unit, and lower the lift all the way back to the ground.
22. Raise the lift back up and listen for the lock latches to engage. These should engage at the same time and since we have not adjusted these yet, it's likely that they will be slightly out of sync. Pay attention to which one engages first and tighten the cable nut on the side that is engaging second. This will raise that carriage to where both are able to engage at the same time. Note: The cable nut that you are adjusting is the one that terminates into the top of the Carriage.
23. Once you are finished adjusting the cables, you can now install the (2) Rubber Door Guards on each Carriage using the hardware provided.
24. Locate the (2) Cylinder Collars that are supplied with the lift. These are used to keep the cylinders from lowering down on their own, if the check valve or release valve bleeds pressure while the carriages are on the locks. Place each collar over the cylinder tube and set them down on the brace welded to the carriage that the cylinder runs through. Tighten the collars so that they do not slide on the cylinder tube.

 **WARNING: DO NOT PERFORM ANY MAINTENANCE OR INSTALLATION OF ANY COMPONENTS WITHOUT FIRST ENSURING THAT ELECTRICAL POWER HAS BEEN DISCONNECTED AT THE SOURCE OR PANEL AND CANNOT BE REENERGIZED UNTIL ALL MAINTENANCE AND/OR INSTALLATION PROCEDURES ARE COMPLETED.**

 **DANGER: DO NOT RUN POWER UNIT WITHOUT FLUID. DAMAGE TO PUMP CAN OCCUR. THE POWER UNIT MUST BE KEPT DRY. DAMAGE TO POWER UNIT CAUSED BY WATER OR OTHER LIQUIDS SUCH AS DETERGENTS, ACID ETC., IS NOT COVERED UNDER WARRANTY.**

7-OPERATION INSTRUCTIONS

! WARNING: LIFT OPERATION BY TRAINED AUTHORIZED PERSONNEL OVER 18 YEARS ONLY. APPLY THE PARKING BRAKE AFTER POSITIONING THE VEHICLE ON THE LIFT. DO NOT ALLOW ANYONE TO STAY IN LIFT AREA DURING RAISING AND LOWERING CYCLES. CLOSELY WATCH THE VEHICLE AND THE LIFT DURING RAISING AND LOWERING CYCLES. OBSERVE THE RATED LOAD CAPACITY AND LOAD DISTRIBUTION. DO NOT ALLOW ANYONE TO CLIMB ON LIFT OR STAY INSIDE VEHICLE. AFTER RAISING THE VEHICLE FRAME 6", STOP AND CHECK ADAPTERS FOR SECURE CONTACT. PERFORM BUMPER TEST. MAKE SURE THE VEHICLE DOORS ARE CLOSED DURING RAISING AND LOWERING CYCLES.

7.1 DEFECTS / MALFUNCTIONS

! WARNING: IN CASE OF DEFECTS OR MALFUNCTIONS SUCH AS JERKY LIFT MOVEMENT OR DEFORMATION OF THE SUPERSTRUCTURE, SUPPORT OR LOWER THE LIFT IMMEDIATELY. CONTACT QUALIFIED SERVICE PERSONNEL.

7.2 CONTROLS

7.2.1 UP CONTROL

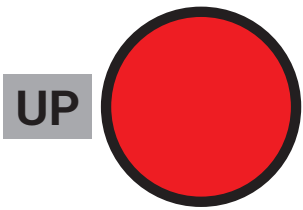

Once the up button is actuated, the lift moves up until the button is released or the limit stop is reached.

7.2.2 SAFETY LOCK CONTROL

The safety latch mechanism will "Trip Over" as the lift raises and drop into each safety latch stop. To lock the lift you must press the lowering handle on the power unit (Fig. 1) to relieve the hydraulic pressure and let the safety locks engage into a level locked position.

POS.	Descriptions	Function
1	Unlocking handle	Release the mechanical locking unit.
2	Lowering handle	Control descending movement. Engage the mechanical locking unit.
3	UP button	Push to control the rising movement.

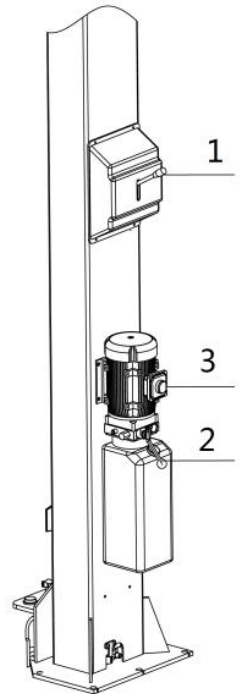

! WARNING: PAY CLOSE ATTENTION WHEN SETTING THE LOCKS. THE LOCKS MUST BE A LEVEL MATCH SET IN ORDER TO AVOID A VEHICLE TILT.

! WARNING: ALWAYS LOCK THE LIFT BEFORE GOING UNDER THE VEHICLE. NEVER ALLOW ANYONE TO GO UNDER THE LIFT WHEN RAISING OR LOWERING.



NOTE: IT IS NORMAL FOR AN EMPTY LIFT TO LOWER SLOWLY - IT MAY BE NECESSARY TO ADD WEIGHT.

7.2.3 LOWERING CONTROL

Press the power button to raise the carriages high enough up off the locks so that they can be disengaged. Press down on the lock release lever located on the power unit column to manually disengage the both locks.



WARNING: BE SURE THAT BOTH LOCKS DISENGAGE BEFORE LOWERING.

Press the lowering handle on the power unit until the lift is completely lowered.

7.3 OPERATION



WARNING: FAILURE TO OPERATE THE LIFT ACCORDING TO THIS MANUAL MAY CAUSE DAMAGE TO THE LIFT, PROPERTY DAMAGE AND/OR PERSONAL INJURY.

25. Before driving a vehicle onto the lift make sure the lift is fully lowered. Before driving a vehicle onto the lift, position the lift arms outward. Do not hit or run over the lifting arms, as this could damage the vehicle and/or lift. Make sure the lift is fully lowered before moving the vehicle over the lift. **NOTE:** It is recommended to swing both arms outward pointing toward the front of the lift prior to loading a vehicle onto the 9KMSC.
26. Drive the vehicle over the lift while keeping the vehicle parallel with the lift and aligning the center of gravity of the vehicle with the center of the lift. **NOTE:** The “Center of Gravity” (COG) of the vehicle is the balance point at which there is equal weight in front of and behind the COG, and equal weight on both sides of the COG. The COG is not necessarily the dimensional center of the vehicle, but is often slightly toward the engine from the dimensional center of the vehicle.
27. Turn off the vehicle’s engine and engage the parking brake of the vehicle.
28. Read the vehicles owner’s manual to identify the recommended vehicle lifting points.
29. Prepare the work area according to this manual. Move the lifting arms inward, and position the rubber pads to contact with the vehicle manufacturer’s recommended lifting points.



IMPORTANT: PLACE THE FOUR RUBBER PADS UNDER EDGE OF VEHICLE AT THE FOUR JACK POINTS.

30. Once the lifting arms have been positioned under the vehicle lifting points, operate the power switch to make contact and lift the vehicle slightly. Test to make sure the vehicle is well balanced and the contact between the rubber pads and vehicle lifting points are secure by performing the “BUMPER TEST.” (pg. 2) Then proceed to lift the vehicle to the desired height.

31.  **WARNING:** Do not lift the vehicle if you cannot establish secure and level lifting points. Do not use sub-standard shims or other devices in place of approved and recommended rubber pad adapters. Never use the lift without the rubber pads in place on each plate and in contact with the lifting points of a vehicle.
32. Press up button and raise vehicle to desired height. Do not go under vehicle until load rests on level safety locks.
33. While lifting the vehicle a clicking sound should be noticeable which indicates the safety mechanism is operating. If this sound is not heard, immediately cease using the lift and call an authorized service agent.
34. When lift reaches maximum height, a limit switch will come into operation and stop the lift. When lift has stopped, press and hold the lowering handle until load rests on level safety locks.
35. Once the repair work to the vehicle is complete, make sure to remove all tools, safety jack stands, and materials from under the vehicle and lift. Also, make sure the work area is clear and it is safe to lower the vehicle.
36. Lower vehicle by pressing the Up button to disengage the safety locks. Pull down on the safety release lever to release the safety locks then press the lowering handle until the lift is completely lowered.
37. Move the lifting arms outward, out of the path of the vehicle. Clear all bystanders, and any objects from work area and direction of vehicle.
38. Disengage the vehicle parking brake. Start the vehicle's engine, and drive the vehicle off the lift slowly and carefully.

 **WARNING: THE OPERATOR MUST BE TRAINED AND AUTHORIZED TO OPERATE THE LIFT.**

 **WARNING: DO NOT GO UNDER VEHICLE UNDER ANY CIRCUMSTANCES WHILE VEHICLE IS BEING RAISED OR LOWERED.**

 **WARNING: LOAD MUST BE EVENLY DISTRIBUTED BETWEEN BOTH LIFTING PLATFORMS. IF LOAD IS UNBALANCED, REPOSITION VEHICLE. DO NOT LOWER ON TO LOCKS AT DIFFERENT HEIGHTS.**

8-MAINTENANCE

 **WARNING: DISCONNECT THE POWER BEFORE SERVICING THE LIFT.**

 **IMPORTANT: THE MAINTENANCE INTERVALS INDICATED BELOW APPLY TO AVERAGE WORKSHOP USE. THE LIFT SHOULD BE INSPECTED MORE FREQUENTLY FOR SEVERE USE APPLICATIONS.**

8.1 MAINTENANCE SCHEDULE

It is important to keep the lift clean, dry, and well maintained by establishing a periodic preventive maintenance program to ensure trouble-free operation and long service life.

8.1.1 DAILY

1. Check safety locking mechanism is functioning correctly.
2. Check safety lock audibly and visually while in operation.
3. Check safety latches for free movement and full engagement with rack.
4. Inspect the condition of rubber lifting pads and replace as necessary if worn or torn.
5. Check hydraulic connections, and hoses for leakage.
6. Check chain connections - Bends, cracks - and looseness.
7. Check for frayed cables in both raised and lowered positions.
8. Check snap rings at all rollers and sheaves.
9. Check bolts, nuts, and screws and tighten.
10. Check wiring & switches for damage.
11. Keep base plate free of dirt, grease or any other corrosive substances.
12. Check floor for stress cracks near anchor bolts.
13. Check swing arm restraints.

8.1.2 WEEKLY

1. Check anchor bolts torque to 85 ft-lbs for the 3/4" anchor bolts.
NOTE: DO NOT USE IMPACT WRENCH.
2. Check floor for stress cracks near anchor bolts.
3. Check hydraulic oil level.
4. Check and tighten bolts and nuts, and screws.
5. Check cylinder pulley assembly for free movement or excessive wear on cylinder yoke or pulley pin.
6. Check cable pulley for free movement and excessive wear.

8.1.3 MONTHLY

1. Check safety mechanism operation.
2. Check condition of shafts, shaft locks and bushings.
3. Check overall cleanliness.

8.1.4 BIMONTHLY

1. Check condition of extensions and lubricate.
2. Check oil leaks from cylinders.
3. Check oil leaks at pipe joints.

8.1.5 YEARLY

Service and safety inspection on the lift must be performed by a competent person. This inspection must be recorded. If the 12 month service and safety inspection is not performed, the warranty is null and void.

1. Lubricate chain, if equipped
2. Grease rub blocks and column surface contacting rub blocks.
3. Change the hydraulic fluid. A good maintenance program makes it mandatory to keep hydraulic fluid clean. Operating temperature, type of service, contamination levels, filtration, and chemical composition of fluid should be considered. If operating in harsh or dusty conditions, a shorter interval may be required.

THE FOLLOWING ITEMS SHOULD ONLY BE PERFORMED BY A TRAINED MAINTENANCE EXPERT.

- Replace hydraulic hoses.
- Replace chains and rollers.
- Replace cables and sheaves.
- Replace or rebuild air and hydraulic cylinders as required.
- Replace or rebuild pumps / motors as required.
- Check hydraulic and air cylinder rod and rod end (threads) for deformation or damage.
- Check cylinder mount for looseness and damage.

Relocating or changing components may cause problems. Each component in the system must be compatible; an undersized or restricted line will cause a drop in pressure. All valve, pump, and hose connections should be sealed and/or capped until just prior to use. Air hoses can be used to clean fittings and other components. However, the air supply must be filtered and dry to prevent contamination. Most important - **CLEANLINESS** - contamination is the most frequent cause of malfunction or failure of hydraulic equipment.

8.1.6 EVERY OTHER YEAR

Hydraulic oil should be replaced.



IMPORTANT: AFTER CLEANING WORKSHOP FLOOR OR LIFT, TO MAINTAIN HOIST EFFICIENCY WE ADVISE TO LUBRICATE LIFTING ARM LOCKING MECHANISM, AND SAFETY LOCKING MECHANISM. CHECK SAFETY LOCKING MECHANISM IS FUNCTIONING CORRECTLY.

8.2 MAINTENANCE BY OPERATOR

All moving parts have been lubricated at the factory and should be re-lubricated before the first use and at least once every six months to prevent damage.

8.2.1 HYDRAULIC SYSTEM

1. Check the fluid level with the lift fully lowered and add fluid as required. Use premium quality ISO-32 or AW-32 hydraulic oil.
2. Visually check all hydraulic hoses and connections for tightness before each use to ensure proper working condition.
3. Lightly oil the cylinder rods at least once every six months or when they become dry.

8.2.2 GREASING POINTS

SLIDE TRACKS:

- The carriage assembly slide tracks should be greased every six months (or more frequently in case of noise generation).
- Slightly grease the slide tracks over their whole length using a brush.

8.2.3 OPERATION AND WEAR CHECKS

1. Examine lift for structural cracks, bends, or other signs of damage prior to each use. Do not use this product if worn or damaged.
2. Check that the safety locking mechanism is functioning correctly.
3. Check that the safety lock is audibly and visibly operating correctly.
4. Check the floor for stress cracks near the anchor bolts.

8.2.4 LIFT STABILITY

1. Every six months check the nuts of all bolts for correct installation torque.
2. Retighten them as required. **NOTE: DO NOT USE AN IMPACT WRENCH.**

8.3 CLEANING

 **DANGER: DO NOT USE HIGH PRESSURE / STEAM JET CLEANERS OR CAUSTIC CLEANING AGENTS.**

1. Periodically wash off aggressive substances and treat the lift with oil or wax spray.
2. Repair the damage to the paintwork immediately to prevent corrosion.

9-TROUBLESHOOTING

- 1. Motor does not run:**
 - A. Breaker or fuse blown.
 - B. Motor thermal overload tripped. Wait for overload to cool.
 - C. Faulty wiring connections.....Call electrician for service.
 - D. Defective up button.....Call electrician for service.
- 2. Motor runs but will not raise:**
 - A. A piece of debris could be stuck in the lowering valve. Push handle down and push the up button at the same time. Hold for 10-15 seconds. This should flush the system.
 - B. Check the clearance between the plunger valve of the lowering handle. There should be 1/16”.
 - C. Remove the check valve cover and clean ball and seat.
 - D. Oil level too low. Oil level should be just under the vent cap port when the lift is in the lowered position.
- 3. Oil blows out breather of power unit:**
 - A. Oil reservoir overfilled.
 - B. Lift lowered too quickly while under a heavy load.
- 4. Motor hums and will not run:**
 - A. Impeller fan cover is dented. Take off and straighten.
 - B. Faulty wiring.....Call electrician.
 - C. Bad capacitor.....Call electrician.
 - D. Low voltage.....Call electrician.
 - E. Lift overloaded.....Reduce weight.
- 5. Lift jerks going up and down: Air in hydraulic system. Raise lift all the way to top and return to floor; Repeat 4-6 times. Do not let this overheat power unit.**
- 6. Oil leaks:**
 - A. Check the power unit: If the power unit leaks hydraulic oil around the tank-mounting flange, check the oil level in the tank. The level should be two inches below the flange of the tank. Check with a screwdriver.
 - B. Check the rod end of the cylinder: If the rod seal of the cylinder is out, rebuild or replace the cylinder.
 - C. Breather end of the cylinder: If the piston seal of the cylinder is out, rebuild or replace the cylinder.
- 7. Lift makes excessive noise:**
 - A. Leg of the lift is dry and requires grease.
 - B. Cylinder pulley assembly or cable pulley assembly is not moving freely.
 - C. May have excessive wear on pins or cylinder yoke.

10-OWNER/EMPLOYER RESPONSIBILITIES

The owner/employer:

Shall establish procedures to periodically maintain, inspect and care for the lift in accordance with the manufactures recommended procedures to ensure it's continued safe operations.

Shall provide necessary lockout / tag outs of energy sources per ANSI Z244.1 - 1982 before beginning any lift repairs. Shall not modify the lift in any manner without prior written consent of the manufacturer.

Shall display this manual or copy supplied with the lift in a conspicuous, dry location in the lift area convenient to the operator.

Shall insure that lift operators are instructed in the safe proper use and operation of the lift using the manufacturer's instructions outlined within this manual supplied with the lift.

11-DIAGRAMS (FIG. 1-11)

FIG. 1 - EXPLODED PARTS VIEW

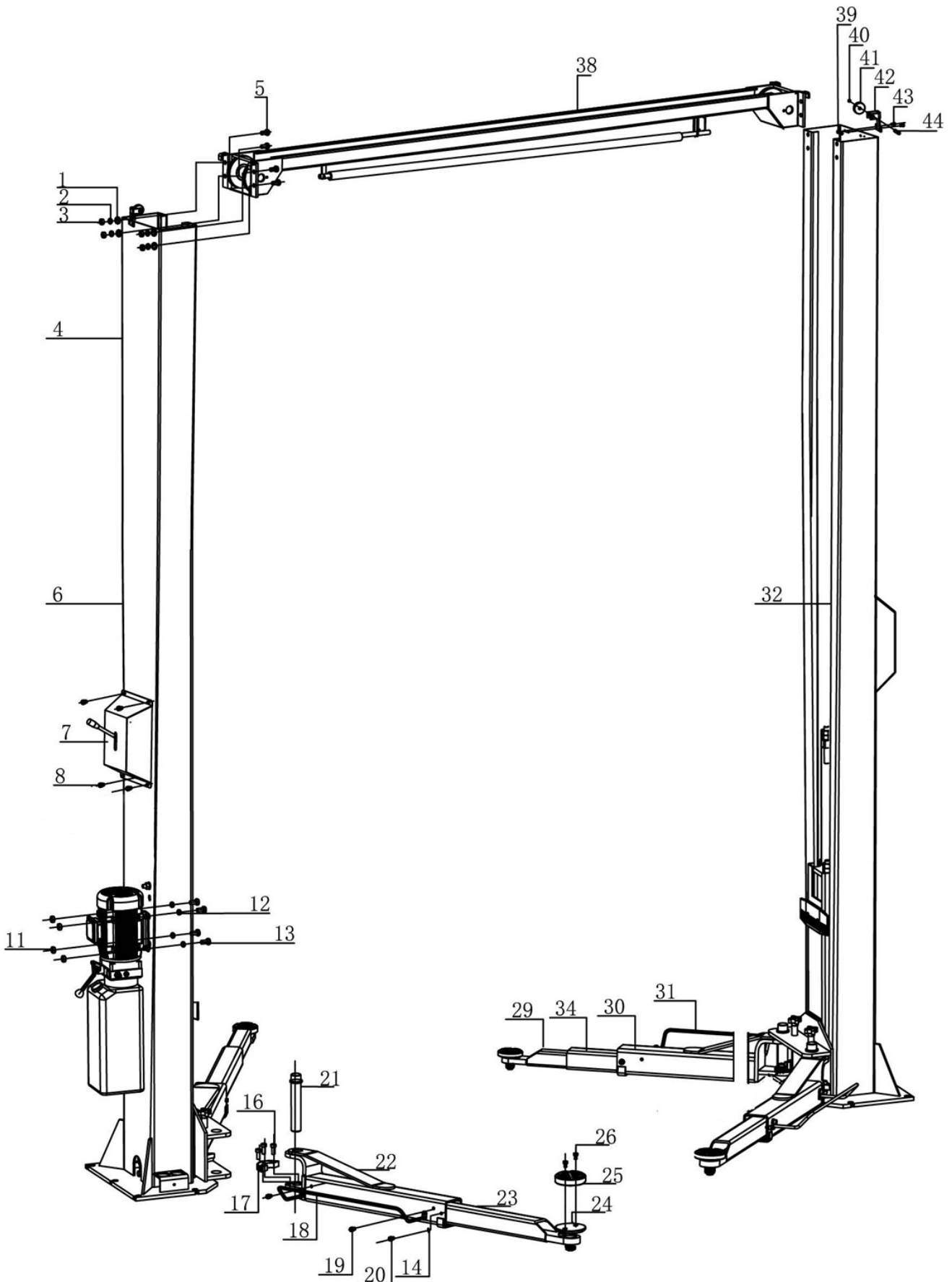

No.	Code	Description	QTY
1	204101008	FLAT WASHER - D14	8
2	204201007	SPRING WASHER - D14	8
3	203101008	HEX NUT - M14	8
5	201102035	HEX BOLT - M14X30	8
6	614901485	POWER UNIT COLUMN	1
7	420680096	LOCK COVER	2
8	202109017	CAP HEAD BOLT- M6X8	8
11	203204103	FLANGE NUT - M8	4
12	420040010	RUBBER ISOLATOR	4
13	201101103	CAP HEAD BOLT - M8X30	4
16	202109085	CAP HEAD BOLT (12.9) - M12X30	12
17	410901074	ARM RESTRAINT GEAR	4
18	614004014B	LONG ARM TOE GUARD	2
19	202110018	CAP HEAD BOLT - M10X12	8
20	202109040	CAP HEAD BOLT - M10X16	4
21	410049031B	ARM PIN	4
22	614004005B	LONG ARM (OUTER)	2
23	614901362	LONG ARM (INNER)	2
24	615004003D	PAD MOUNT ASSEMBLY	4
25	420040250	RUBBER PAD (ROUND)	4
26	202111004	CAP HEAD BOLT - M8X12	8
29	614004011C	SHORT ARM (INNER)	2
30	614004007C	SHORT ARM (OUTER)	2
31	614004012B	SHORT ARM TOE GUARD	2
32	614901377	OFFSIDE COLUMN	1
34	614004009C	SHORT ARM (MIDDLE)	2
38	614901379	CROSSBEAM	1
39	203103006	LOCKING HEX NUT - M8	4
40	204301001	C-CLIP	4
41	420080030	SAFETY RELEASE CABLE PULLEY	2
42	410060573	SAFETY RELEASE CABLE PULLEY BRACKET	2
43	202109029	CAP HEAD BOLT - M8X20	4
44	410080271	SHAFT	2

FIG. 2 - ADAPTERS

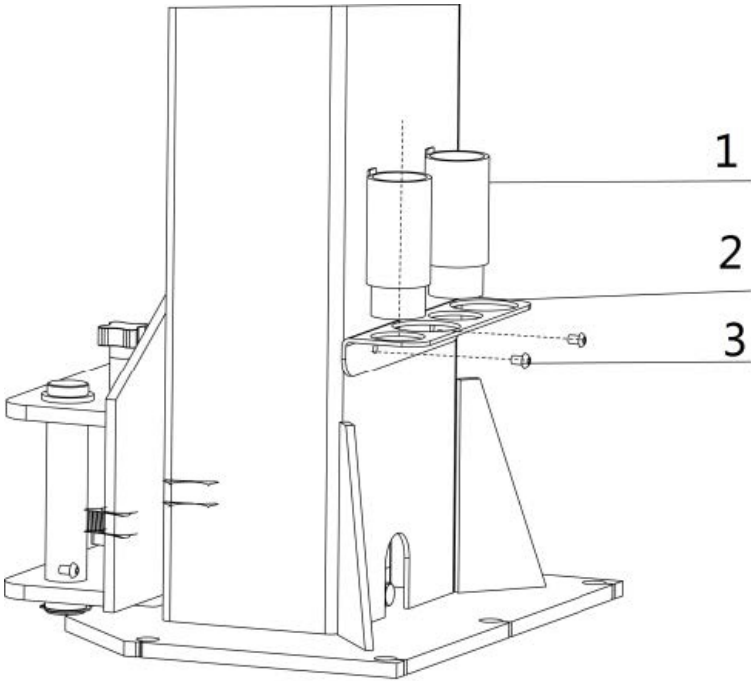

No.	Code	Description	QTY
1	612004003B	TRUCK ADAPTER (4"HEIGHT)	4
2	410901744	TRUCK ADAPTER BRACKET	2
3	202110004	BUTTON HEAD BOLT- M8X12	4

FIG. 3 - CARRIAGE

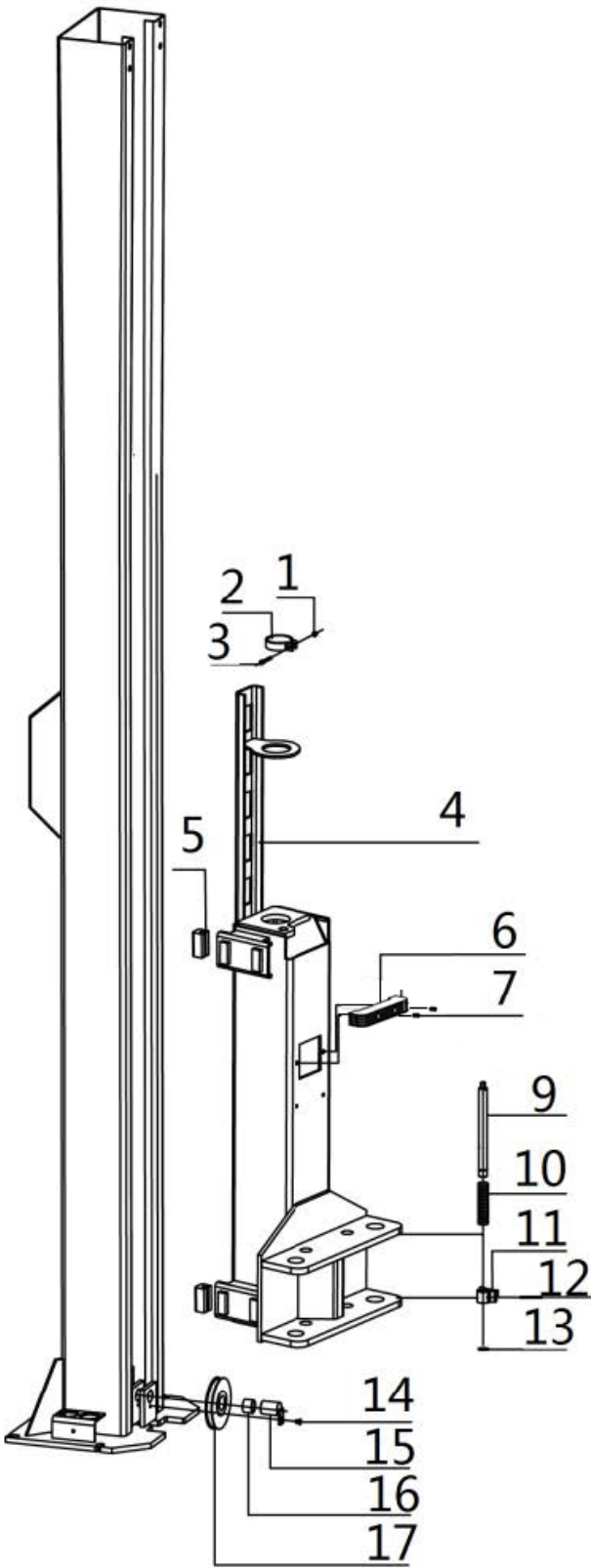

No.	Code	Description	QTY
1	203103005	LOCKING HEX NUT - M6	2
2	410170101B	CYLINDER COLLAR	2
3	202109096	CAP HEAD BOLT - M6X40	2
4	614901378	CARRIAGE	2
5	420680083	NYLON SLIDE BLOCK	16
6	420680124	RUBBER DOOR GUARD PAD	2
7	202109031	HEX HEAD SCREW - M8X12	4
9	410902001	ARM RESTRAINT PIN	4
10	410150121	PRESSURE SPRING	4
11	410901075	ARM RESTRAINT PIN LOCKING TEETH	4
12	206102013	TENSION PIN - D6X40	4
13	204301009	C-CLIP - D25	4
14	202111004	FLAT HEAD BOLT - M8X12	2
15	612056001	LOWER PULLEY SHAFT	2
16	205101101	BUSHING	2
17	410902109	PULLEY	2

FIG. 4-1 - CABLE

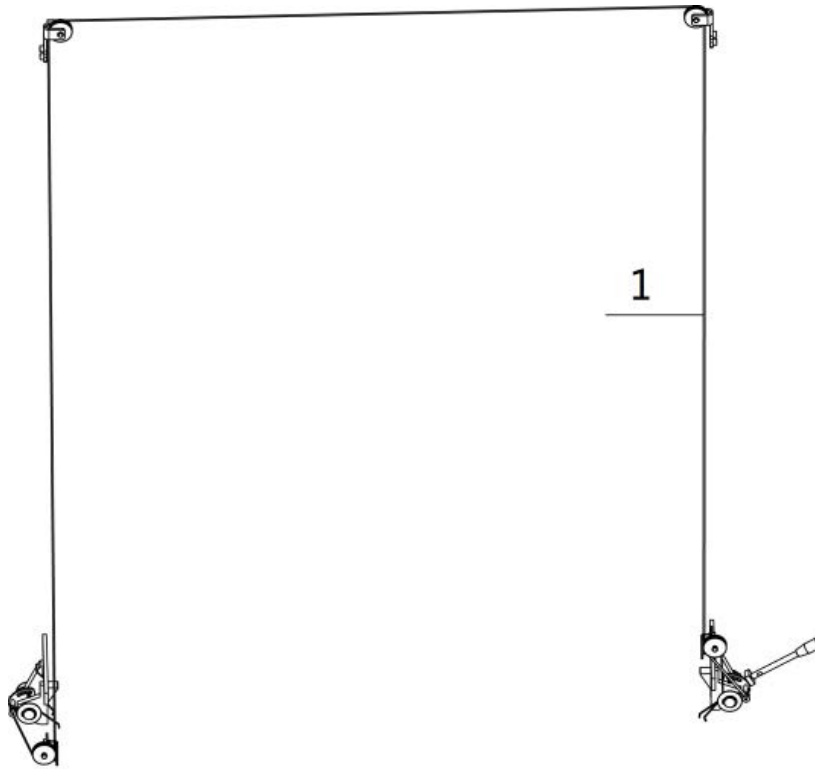

No.	Code	Description	QTY
1	410902490	SAFETY RELEASE CABLE - L=6880MM (271.87")	1

FIG. 4-2 - CROSSBEAM

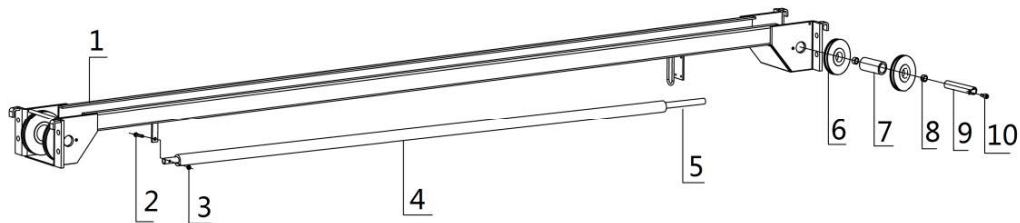

No.	Code	Description	QTY
1	614901379	OVERHEAD CROSSBEAM	1
2	202109024	CAP HEAD BOLT - M6X35	1
3	203103005	LOCKING NUT - M6	1
4	420060010	BLACK FOAM COVER	1
5	410060013	OVERHEAD SHUT OFF BAR	1
6	410902109	PULLEY	4
7	410902029	SPACER	2
8	205101101	BUSHING	4
9	612054507	PULLEY SHAFT	2
10	202111004	CAP HEAD BOLT - M8X12	2

FIG. 5 - SAFETY LOCKS

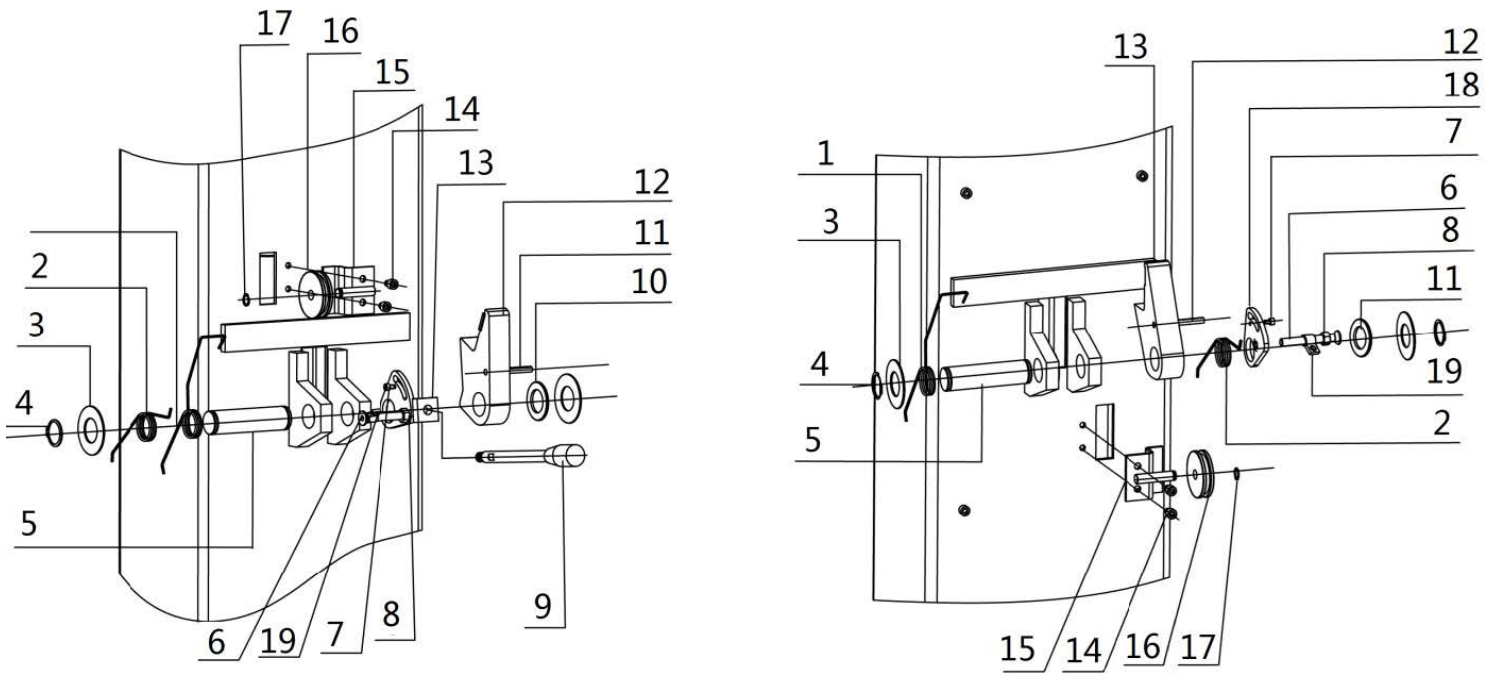

No.	Code	Description	QTY
1	410902013	SPRING (HOOKED END)	2
2	410902014	SPRING (ANGLED END)	2
3	410010031	WASHER	4
4	204301009	CIRCLIP - D25	4
5	410902031	SHAFT	2
6	202111033	FLAT HEAD SCREW - M8X65	2
7	202109005	CAP HEAD BOLT - M4X6	2
8	203101005	HEX NUT - M8	4
9	615068400	LOCK RELEASE HANDLE ASSEMBLY	1
10	420680066	NYLON SPACER - 25X41X25	2
11	206102013	TENSION PIN - D6X40	2
12	615068399B	LOCK LATCH	2
13	611901420	LOCK RELEASE PLATE (WITH HANDLE MOUNT)	1
14	202109017	CAP HEAD BOLT - M6X8	8
15	614006012B	LOCK RELEASE PULLEY MOUNT	2
16	420080030	LOCK RELEASE PULLEY	2
17	204301001	C-CLIP - D10	2
18	410540530	LOCK RELEASE PLATE (OFFSIDE)	1
19	410902484	SAFETY RELEASE CABLE MOUNT	2

FIG. 6 - HOSES/POWER UNIT

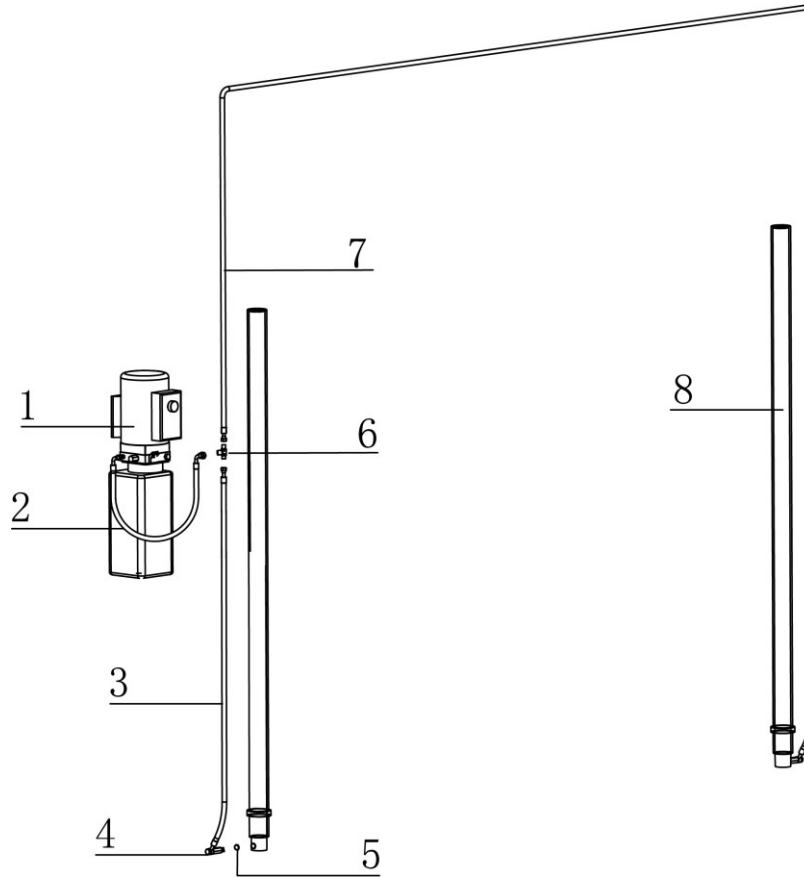

No.	Code	Description	QTY
1		POWER UNIT - 2.2KW	1
2	624008106	HYDRAULIC HOSE - L=430MM	1
3	624008104	HYDRAULIC HOSE - L=1270MM	1
4	615015003	HYDRAULIC CYLINDER EXTENSION- M14*1.5-G1/4	2
5	207103025	COMBINATION WASHER	4
6	615006003	HYDRAULIC TEE FITTING	1
7	624008107	HYDRAULIC HOSE - L=8860MM	1
8	615017013	DIRECT DRIVE CYLINDER	2

FIG. 7 - CABLES / PULLEYS

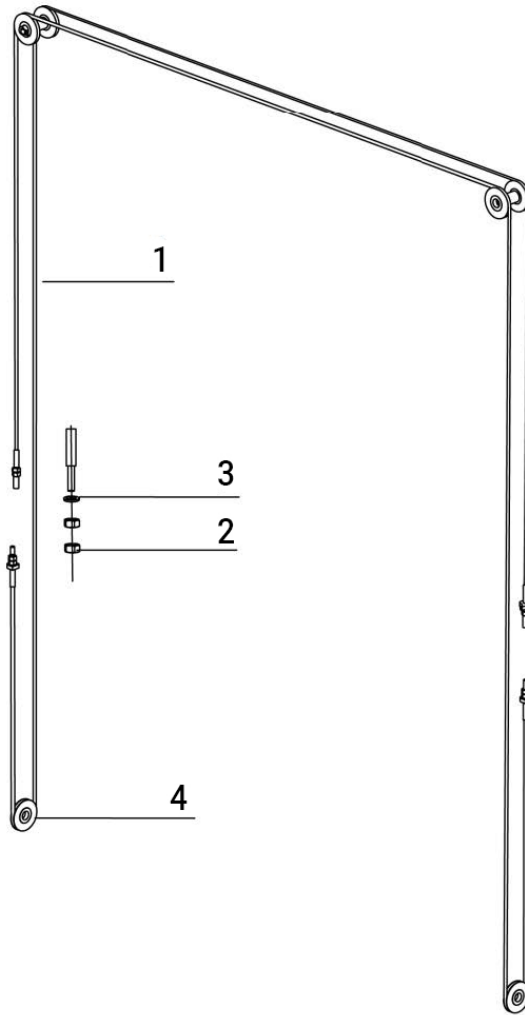

No.	Code	Description	QTY
1	615008006	STEEL CABLE L=9620	2
2	203101009	HEX NUT - M16	8
3	204101009	FLAT WASHER - M16	4
4	410902109	PULLEY	2

FIG. 8 - POWER UNIT

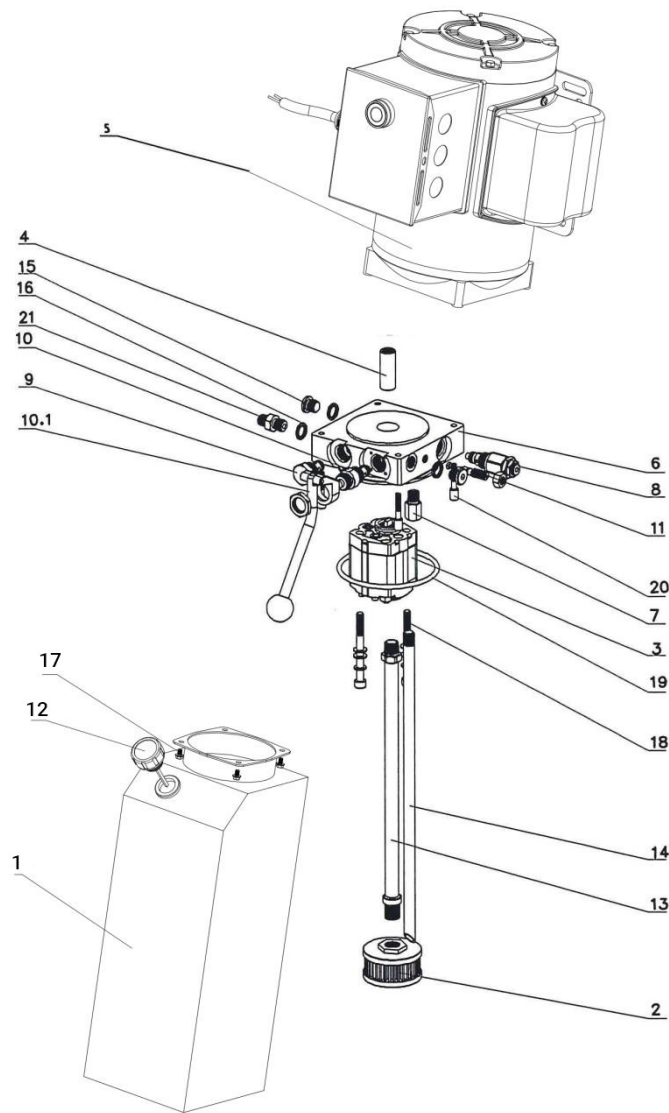

No.	Code	Description	QTY
1	330405069	OIL TANK (STEEL)	1
2	330403003	OIL FILTER	1
3	330201006	GEAR PUMP	1
4	330404015	COUPLING 46MM	1
5	320204209	MOTOR - (208-240V,50/60HZ,2.2KW,2850/3450RPM)	1
6	330105017	HYDRAULIC BLOCK	1
7	330301003	PRESSURE BYPASS VALVE	1
8	330304010	PRESSURE ADJUSTMENT VALVE	1
9	330302008	CHECK VALVE	1
10	330303016	LOWERING VALVE	1
10:1	330303015	LOWERING VALVE HANDLE	1
11	330313001	THROTTLE VALVE	1

No.	Code	Description	QTY
12	330502015	VENTED OIL CAP	1
13	330401013	PICKUP TUBE	1
14	330402006	RETURN TUBE	1
15	210101013	PLUG - M14*1.5	2
16	207103025	COMBINATION WASHER	3
17	202109144	BOLT - M5X18	4
18	202109072	CAP HEAD BOLT - M8X85	2
19	207101098	O-RING - 109*5.3	1
20	202109145	BOLT	4
21	330600005	HYDRAULIC STRAIGHT CONNECTOR	1

FIG. 9 - HYDRAULICS

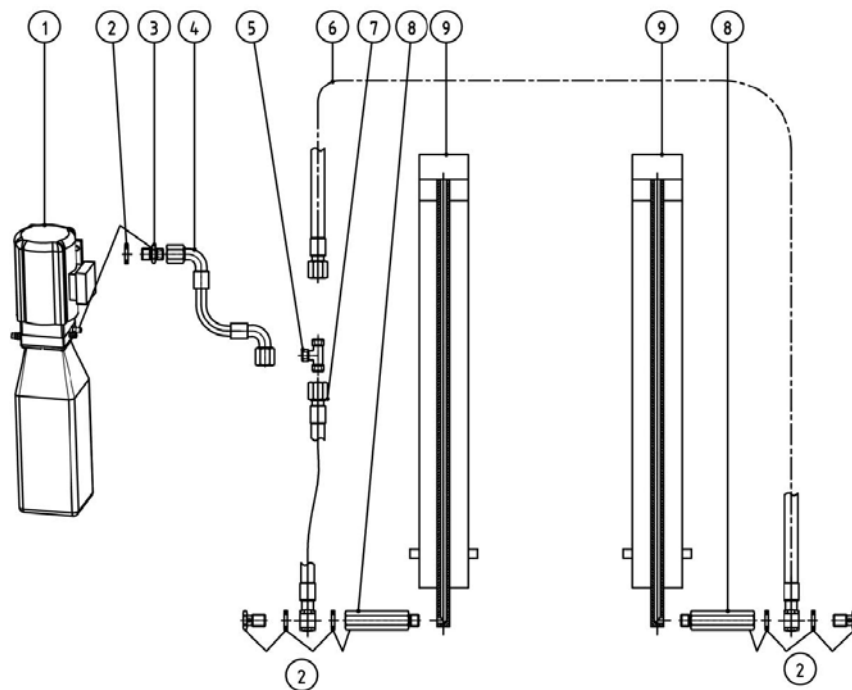

No.	Code	Description	QTY
1		POWER UNIT - 2.2KW	1
2	207103025	COMBINATION WASHER	1
3	330600005	HYDRAULIC STRAIGHT CONNECTOR	1
4	624008106	HYDRAULIC HOSE - L=430MM	1
5	615006003	HYDRAULIC T-FITTING	1
6	624008107	HYDRAULIC HOSE - L=8860MM	1
7	624008104	HYDRAULIC HOSE - L=1270MM	1
8	615015003	HYDRAULIC CYLINDER EXTENSION- M14*1.5-G1/4	2
9	615017013	HYDRAULIC CYLINDER	2

FIG. 10 - ELECTRICAL

No.	Code	Description	QTY
SQ1	320301011	CARRIAGE LIMIT SWITCH	1
SQ2	320301002	OVERHEAD LIMIT SWITCH	1

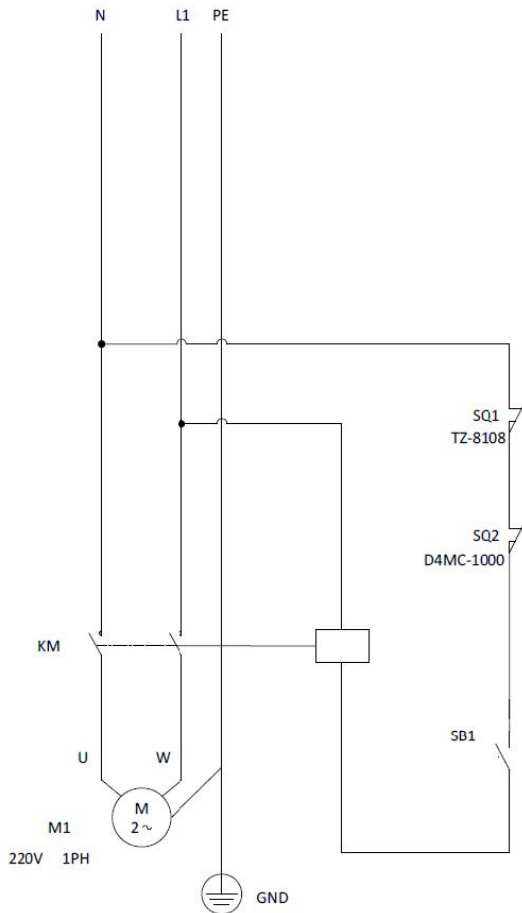

Wire L is going to be fixed with terminals A1, 3L2 and 1L1.
 Wire N is going to be fixed with terminals 5L3 and 13NO.
 Wire U is going to be fixed with terminals 2T1 and 4T2.
 Wire W is going to be fixed with terminals 6T3 and 14NO.

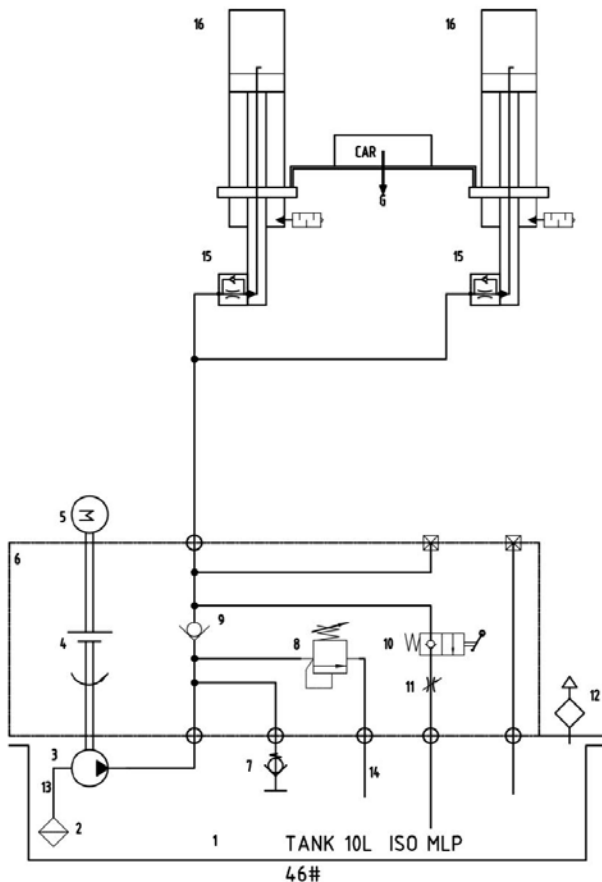
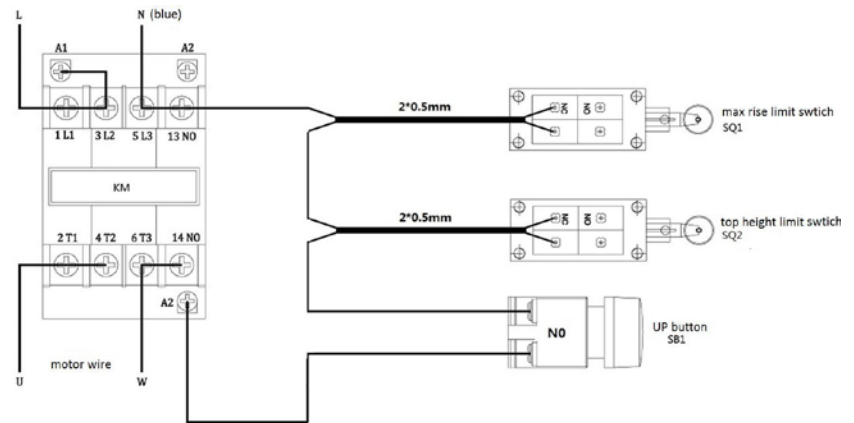

- 1.oil tank
- 2.oil sucking filter
- 3.gear pump
- 4.coupling
- 5.motor
- 6.hydraulic block
- 7.cushion valve
- 8.overflow valve
- 9.single way valve
- 10.manual unloading valve
- 11.flow control valve
- 12.oil tank cover
- 13.oil-sucking pipe
- 14.oil-returning pipe
- 15.composite connector
- 16.oil cylinder

FIG. 11 - DIMENSIONS

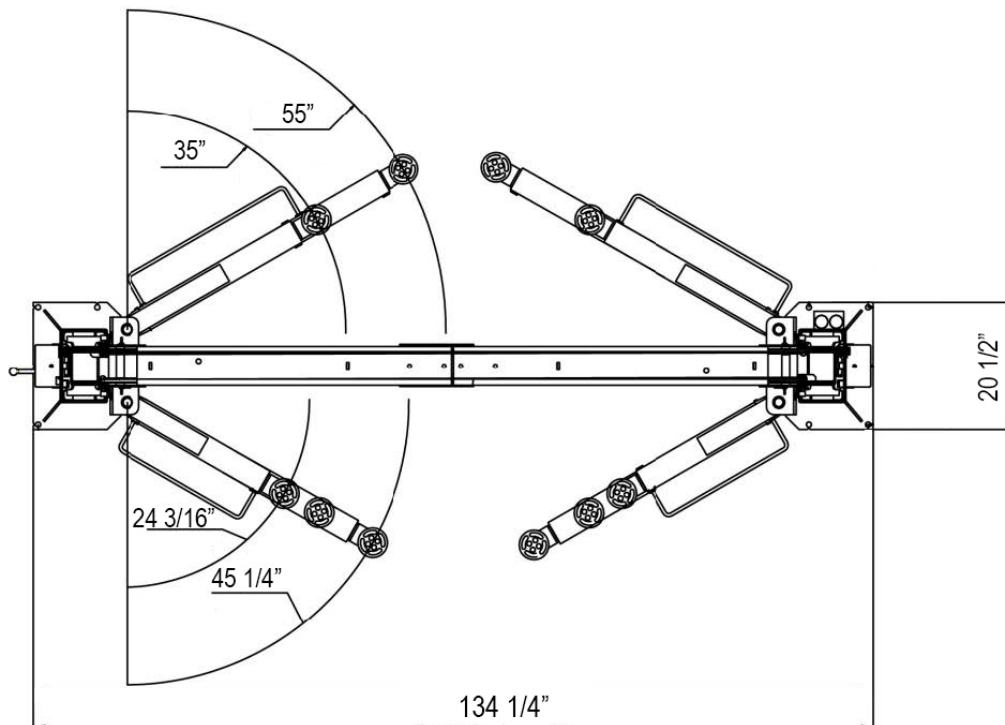
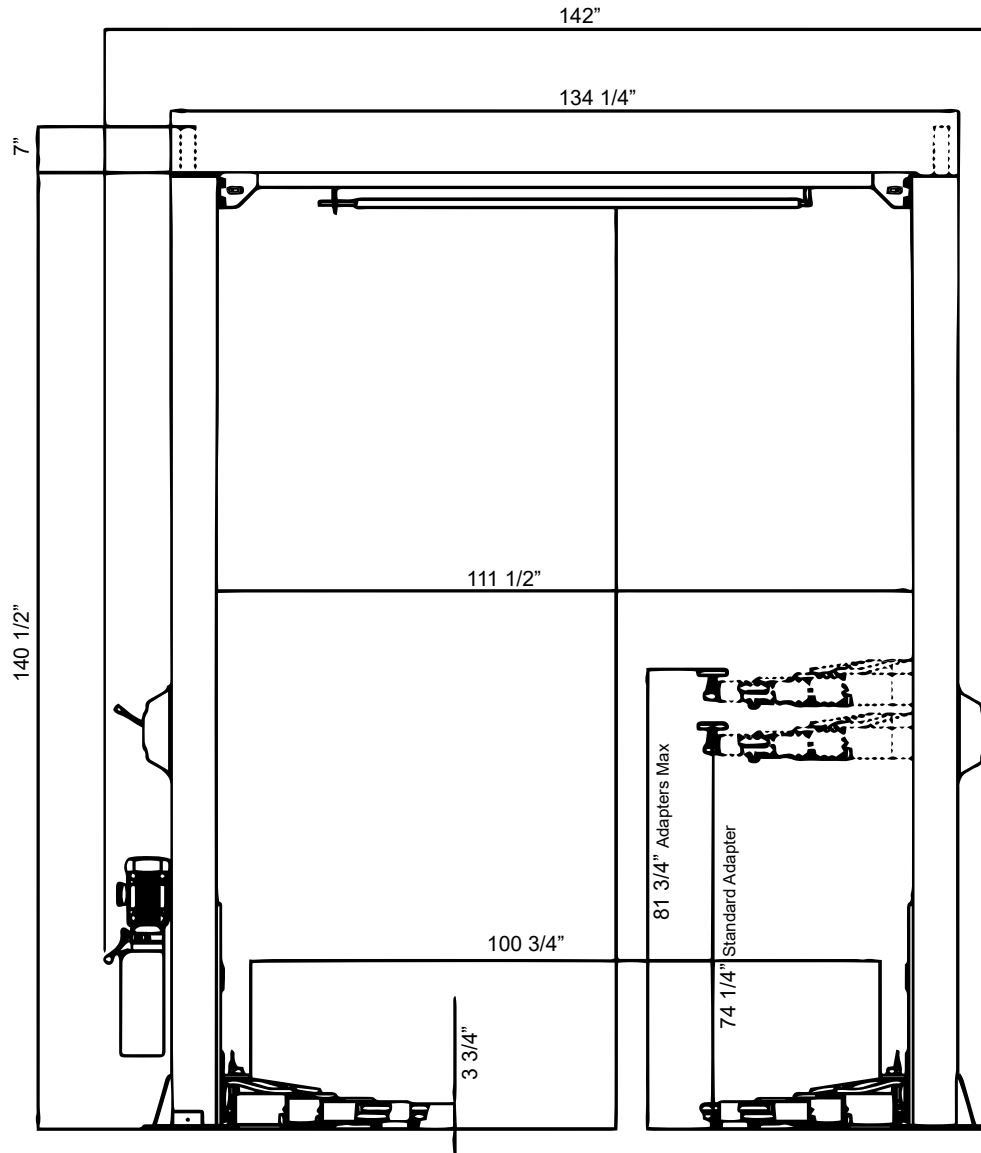



LIMITED WARRANTY

The **Titan 2 Post lifts, 4 Post lifts and Bridge Jacks** are backed by a standard **1-year** replacement parts warranty and a **5-year** structural warranty from the date of purchase, to the original purchaser only. The **1-year** replacement parts warranty covers power units, hydraulic cylinders, and all other assembly components such as, but not limited to: turn plates, slip plates, cables, chains, valves, switches etc. This does not cover normal wear items such as, but not limited to: rubber lifting pads and nylon slide blocks. Titan Elite model lifts have been discontinued but still qualify under the same terms as shown above.

Titan Master Series, SL-6600 Scissor Lifts and PREMIER Series 2 Post Lifts are backed by a **2-year** replacement parts warranty and a **5-year** structural warranty from the date of purchase, to the original purchaser only. The **2-year** replacement parts warranty covers power units, hydraulic cylinders, and all other assembly components such as, but not limited to: valves, switches, capacitors etc. This does not cover normal wear items such as, but not limited to: rubber lifting pads, nylon slide blocks and rubber arm pads. **Titan Master Series** includes lifetime warranty on nylon slide blocks.

Titan MRL-6000 Scissor lifts are backed by a standard **1-year** replacement parts warranty and a **5-year** structural warranty from the date of purchase, to the original purchaser only. The **1-year** replacement parts warranty covers power units, hydraulic cylinders, and all other assembly components such as, but not limited to: valves, switches, capacitors etc. This does not cover normal wear items such as but not limited to rubber lifting pads.

Titan ROT-4500 Rotisseries are backed by a standard **1-year** replacement parts warranty from the date of purchase, to the original purchaser only. The **1-year** replacement parts warranty covers components such as, but not limited to: hydraulic cylinders, caster assemblies, bearings etc. This does not cover normal wear items such as, but not limited to, mounting adapters.

Titan Standard Duty and Heavy Duty motorcycle lifts are backed by a standard **1-year** replacement parts warranty from the date of purchase, to the original purchaser only. The **1-year** replacement parts warranty covers power units, hydraulic cylinders, pneumatic cylinders, and all other assembly components such as, but not limited to: cables, caster wheels, valves, switches, wheel vises etc. This does not cover normal wear items such as, but not limited to: rubber wheel vise pads.

Titan Light Duty motorcycle lifts are warranted for replacement parts only to the original purchaser for a period of **90 days** from the date of purchase. This **90 day** replacement parts warranty covers items such as, but not limited to: hydraulic cylinder, casters, pedal assemblies, wheel vises etc. This does not cover normal wear items such as, but not limited to: rubber wheel vise pads.

Titan Bulldog Moto Cradle Wheel Chock is warranted for replacement parts, only to the original purchaser, for a period of **2-years** from the date of purchase.

XL Tool by Titan Wheel Service Machines and Helper Arm Assemblies are backed by a standard **1-year** replacement parts warranty from the date of purchase, to the original purchaser only. The **1-year** replacement parts warranty covers internal boards, motors, pneumatic cylinders, and all other assembly components such as, but not limited to: cabinet, switches, valves, fittings etc. This does not cover normal wear items such as but not limited to: rubber pads, jaw protectors, air hoses, quick nut assemblies.

Titan shop equipment products and accessories are warranted for replacement parts only to the original purchaser for a period of **90 days** from the date of purchase. This **90 day** replacement parts warranty covers products such as but not limited to: EZ -Mover Jacks, Mini Jacks, tie down products, wheel service accessories, Bulldog Moto Cradle Wheel Chock accessories, dollies, stands, Multi-purpose Jacks, etc.

Titan TJ1T, FJ2T, and FJ3T are warranted for replacement parts only to the original purchaser for a period of **1 year** from the date of purchase.

All non-serialized items will require proof of purchase in the form of a sales receipt from an authorized Titan Lifts dealer showing the date of purchase for any warranty consideration.

For **all** warranty considerations, Titan Marketing, LLC will supply replacement parts only during the warranty period. The original purchaser is responsible for all shipping, handling, and any labor charges incurred. Hydraulic/Pneumatic cylinders may qualify for exchange under warranty if reported within the first 30 days from date of sale. After the first 30 days from date of sale, a seal kit and installation instructions will be sent for cylinder repairs. All defective parts must be returned to Titan for inspection and examination. Any parts that are found to be defective will be replaced or repaired to proper working order. Other items not listed above may be considered general wear parts and therefore, will not be covered under warranty. These warranties **do not** extend to **defects** caused by ordinary wear, abuse, misuse, shipping damage, improper installation, voltage or lack of required maintenance. Titan Marketing, LLC is **not** to be held responsible for any **failure** that results from an accident, purchaser/operator abuse, neglect, or failure to operate products in accordance with instructions provided in the owner's manual(s) supplied. Damage caused by rain, excessive humidity, corrosive environments or other contaminants are not covered under warranty. **THESE WARRANTIES DO NOT EXTEND TO ANY COSMETIC DEFECT NOT INTERFERING WITH EQUIPMENT FUNCTIONALITY OR ANY INCIDENTAL, INDIRECT, OR CONSEQUENTIAL LOSS, DAMAGE, OR EXPENSE THAT MAY RESULT FROM ANY DEFECT, FAILURE OR MALFUNCTION OF A TITAN MARKETING LLC PRODUCT OR THE BREACH OR DELAY IN PERFORMANCE OF THE WARRANTY.**

P.O. Box 7069 • Greenwood, IN 46142 • Ph. 888-908-4826 • Fx. 317-215-2770 • www.titanlifts.com

WARRANTY REGISTRATION

In order to utilize the warranty on this Titan Lifts product, you must register your product with us. The simplest way to do this is to visit [TITANLIFTS.COM/WARRANTIES](https://www.titanlifts.com/warranties) and submit your information online. If you prefer to send your information through the mail, please fill out the form below and send this page to us at :

**Titan Lifts
PO Box 7069
Greenwood, IN 46142**

EQUIPMENT MODEL: _____ SERIAL NUMBER: _____
TYPE OF POWER UNIT: _____ SERIAL NUMBER: _____
DATE OF PURCHASE: _____
PLACE PURCHASED: _____
NAME: _____
STREET: _____
CITY, STATE, ZIP: _____
PHONE: _____
EMAIL: _____

OPT OUT OF PROMOTIONS



In order to receive your warranty, return this card or visit [TITANLIFTS.COM/WARRANTIES](https://www.titanlifts.com/warranties) within 30 days.

 **WARNING** 

The warnings, precautions and instructions in this manual cannot cover all possible conditions and situations that may occur. The operator must understand that the operator must supply common sense and examine caution factors when using this product to determine safety in all circumstances being used.



TITAN MARKETING, LLC

PO Box 7069 Greenwood, IN 46142
1.888.908-4826 FAX (317) 215.2770
www.titanlifts.com

**Patent No.: US 8,104,588 B2
CA 2,729,670**

4/9/24