



INSTALLATION, OPERATION, & MAINTENANCE MANUAL



MODEL:

**SDML-1000D / SDML-1000D-XLT
1,000 LB CAPACITY PNEUMATIC MOTORCYCLE/ATV LIFT**

***OPTIONAL EQUIPMENT SHOWN**

⚠ FOLLOW THIS MANUAL CAREFULLY TO ENSURE THE MACHINE WILL FUNCTION CORRECTLY AND PROVIDE MANY YEARS OF DEPENDABLE SERVICE. FAILURE TO FOLLOW THESE INSTRUCTIONS AND SAFETY WARNINGS MAY RESULT IN PERSONAL INJURY OR PROPERTY DAMAGE. USE OF STRAPS IS RECOMMENDED - SOLD SEPARATELY. KEEP THIS MANUAL IN A SAFE DRY PLACE FOR FUTURE REFERENCE.



TITAN MARKETING, LLC

PO Box 7069 Greenwood, IN 46142
1.888.908-4826 FAX (317) 215.2770
www.titanlifts.com

To Our Valued Customers:

Thank you for purchasing a Titan Lifts® product. We hope this high quality equipment provides you with years of dependable service.

It is unfortunate that rare situations may occur with the products you purchase from Titan Lifts®. We value your business as well as the trust you have and need to maintain your relationship with us. Titan Lifts® carries liability coverage that may protect our customers if a situation does occur. However, as in all accidents there must be proof of liability for a claim to be made. Our insurance company requires the following procedures be observed in order to consider a claim:

- A. The claimant must contact the Titan Lifts® distributor immediately with the facts of the situation.
- B. If any equipment is damaged, including vehicles or shop equipment, Titan Lifts® must be given the opportunity to send an impartial representative to the site for proper assessment of the situation.
- C. The Vehicle cannot be moved until either an impartial representative has reviewed the accident or clear and precise pictures are taken that reflect all the pertinent information for an impartial representative to be able to access the information from a distance. Titan Lifts® or its representatives must approve the pictures before anything can be moved.
- D. If any potential liability is determined on behalf of Titan Lifts®, two estimates must be submitted for damages to be reimbursed.

It is imperative that the claimant complies with these procedures, because without proper assessment of the situation a claim will be denied.

ARBITRATION NOTICE

The installation or use of this equipment shall constitute an acknowledgement that the user agrees to resolve any and all disputes or claims of any kind whatsoever, which relate in any way to the equipment, by way of binding arbitration, not litigation. No suit or legal action may be filed in any state or federal court. Any arbitration shall be governed by the Federal Arbitration Act, and administered by the American Mediation Association, Indianapolis Indiana. The maximum amount that an arbitrator may award and all damages shall not exceed the retail value of this equipment.

WARRANTY NOTICE

This equipment must be assembled and used in the manner according to the documentation provided to be covered by warranty.

Damaged or missing components must be reported within 72 hours of receipt to your freight carrier and to the distributor. Claims must be filed to cover cost.

If you have any questions or if we can be of any further assistance, please don't hesitate to contact a Titan Lifts® representative at 1-888-908-4826. Thank you for the opportunity to continue to serve your lift equipment needs.

CONTENTS

INSTRUCTIONS	1
UNPACKING AND SET-UP *REFER TO PARTS LIST FIG. 1	1
OPERATION & MAINTENANCE.....	2
SAFETY PRECAUTIONS	3
FRONT WHEEL CLAMP	4
INSTALLATION DRAWING	4
FRONT EXTENSION	4
INSTALLATION DRAWING	4
SIDE EXTENSIONS	5
INSTALLATION DRAWING (XLT ONLY)	5
PARTS LIST (FIG. 1)	6
PARTS LIST (FIG. 1) - CONTINUED.....	7
FOOT VALVE PARTS DETAIL (FIG. 2).....	8
ROLLER DROP-OUT PARTS DETAIL (FIG. 3)	9

INSTRUCTIONS



WARNING: READ ENTIRE MANUAL AND COMPLY WITH ALL SAFETY AND SERVICE PRECAUTIONS. DEATH, PERSONAL INJURY AND/OR PROPERTY DAMAGE MAY OCCUR IF INSTRUCTIONS ARE NOT FOLLOWED CAREFULLY.

UNPACKING AND SET-UP *REFER TO PARTS LIST FIG. 1

1. Carefully unpack the lift making sure that all of the parts have been included.
2. Remove the lift and all parts from delivery pallet and place on a clean, solid flat surface.
3. Safely, manually lift the Deck Plate (57) so that the Safety Bar (46) sits within the first safety latch. It is recommended at least two people perform this function.
4. XLT ONLY: Remove one of the Stabilization Pipe Caps (26) from the Stabilization Bar (27). Slide the stabilization bar through the square tubing of the Outside Lifting Arm (28) and place the stabilization cap back on the end. Secure the Stabilization Bar in place with the steel Ball Pins (25).
5. If using the Front Extension (55), slide the front extension over the front of the deck plate so that the support pipe holes align. Hold the front extension in place by connecting the Eye Bolts (56) with a Washer $\Phi 10$ (23) and Nut M10 (24) (Optional Equipment).
6. Take the Fixed Clamp (63) and bolt it to the Deck Plate (57) or Front Extension (55) using the provided bolts (64), Washers $\Phi 10$ (23) and Nuts M10 (24). Insert the Tire Stop (61) onto the Fixed Clamp using the Pin (62) (Optional Equipment).
7. Take the Crank Assembly (60) and bolt it to the Deck Plate (57) or Front Extension (55) using the Provided Bolts (64.1), Washers $\Phi 10$ (23) and Nuts M10 (24). Bolt Moveable Clamp (84) to Crank Assembly (60) using the provided Bolts (81) (Optional Equipment).
8. If using the Side Extensions (52), slide the Support Pipes (53) through Support Pipe holes in the front and rear of the Deck Plate (57). Slide the Side Extensions over the Support Pipes and secure in place with the Quick Pins (54).
9. Hook the Ramp (58) and Extension Panels (51) onto the back of the Deck Plate (57) and Side Extensions (52).
10. Take ends of Air Hose (2) and attach to Foot Operated Air Valve (1) and the Front Cover (6) of the cylinder.
11. Attach compressed air to the Foot Operated Air Valve (1) to 100 PSI air supply and raise the lift by moving the valve to the up position. Requires 90-100PSI air supply.



WARNING: The lift may be damaged and/or personal injury may result if the pressure exceeds the maximum 100 PSI rating.

NOTE: Use caution that mounting bolts for Fixed Clamp (63) do not interfere with the frame support bar movement when using the front extension.

NOTE: Standard Dropout Plate (59) can be removed for easy rear wheel removal. Roller Dropout Plate (78) can be installed after motorcycle is loaded for easy rear wheel cleaning or maintenance.



WARNING: Roller Dropout Plate (78) must be removed prior to unloading the motorcycle from the lift & replaced with the Standard Dropout (59). Do NOT operate motorcycle on Roller Dropout (78). Roller Dropout (78) is not to be used as a dyno device.

OPERATION & MAINTENANCE

*REFER TO PARTS LIST FIG. 1

* TEST THE LIFT SEVERAL TIMES FOR PROPER OPERATION BEFORE ATTEMPTING TO LIFT A LOAD.

1. All moving parts have been lubricated at the factory and should be re-lubricated before the first use and at least once every six months to prevent damage. Grease fittings are located at each frame pivot shaft and at the top ends of the inside frame assembly.
2. Lightly oil cylinder rod at least once every six months or when it becomes dry.
3. Squirt some oil through the bleed hole in the plate at the end of the cylinder to lubricate piston and seal every six months.
4. The pivot shaft set screws should be checked frequently to be sure they are tight. These are located at the top end of the inside frame assembly.
5. Do NOT use this product if worn or damaged. Examine lift for structural cracks, bends, or other signs of damage prior to each use. Check all hoses and connections before each use to ensure proper working condition.
6. Keep lift clean, dry, and well maintained to extend longevity of the product.
7. Roll motorcycle onto Deck Plate (57) until wheel is inside the Clamp (84 & 63).
8. Tighten the clamp to the tire by using the crank handle on the Moveable Clamp (60).
9. Load must be centered on the table at all times.
10. Load must be firmly positioned and secured on the table at all times.
11. To raise the lift, make sure that the compressed air is connected and use the Foot Operated Air Valve (1) until you reach the desired working height.
12. **IMPORTANT:** After reaching the desired working height, lower the lift so that the Safety Bar (46) sits firmly in the safety latch and all pressure is off of the Cylinder (20). Remove air supply from Foot Operated Air Valve (1).
13. When finished working, attach air supply to Foot Operated Air Valve (1), raise the lift to release the Safety Bar (46) and place it back into Deck Plate (57). Slowly release the air from the Cylinder (20) until the lift rests gently on the ground.

WARNING

The warnings, precautions and instructions in this manual cannot cover all possible conditions and situations that may occur. The operator must understand that the operator must supply common sense and examine caution factors when using this product to determine safety in all circumstances being used.

SAFETY PRECAUTIONS

1. Load should not exceed rated capacity for this lift - 1,000lb
2. 90-100PSI shop air needed. Do **NOT** exceed the 100 PSI rating.
3. Make sure the safety bar is down in the locked position while the lift is in the raised position.
4. Move the lift only when it is lowered.
5. Do **NOT** ride vehicle onto lift.
6. Only trained people should operate the lift.
7. Foot operated air valve should be at least 3 feet away when operating. Remain clear of the lift when raising or lowering.
8. Indoor use recommended.
9. Do **NOT** move lift while loaded.
10. Keep hands, tools and other extremities from under carriage and moving parts.
11. Maintain a safe working environment. The work area should be clean, dry, clutter free and sufficiently lit.
12. Wear proper ANSI-approved safety attire. Do **NOT** wear loose fitting clothing while operating lift, long hair and sleeves should be secured.
13. Keep children and bystanders away from work area. Do **NOT** let children operate or play on lift.
14. Do **NOT** use if under the influence of drugs or alcohol. Operator must be alert at all times when using heavy lift equipment.
15. Never operate the lift with someone on it.
16. Use this lift only for the work it is intended. Do **NOT** use this product for an application for which it was not designed. Misuse can lead to personal injury and/or property damage.
17. Industrial applications must follow OSHA requirements.
18. Do **NOT** use for aircraft purposes.
19. Have your lift serviced by a qualified technician using only identical Titan Lifts® replacement parts and attachments. This will ensure that the safety of the lift is maintained.

PLEASE READ THE FOLLOWING CAREFULLY

THE MANUFACTURER AND/OR DISTRIBUTOR HAS PROVIDED THE PARTS LIST AND ASSEMBLY DIAGRAM IN THIS MANUAL AS A REFERENCE TOOL ONLY. THE MANUFACTURER OR DISTRIBUTOR DOES NOT MAKE ANY REPRESENTATION OR WARRANTY OF ANY KIND TO THE BUYER THAT HE OR SHE IS QUALIFIED TO MAKE ANY REPAIRS TO THE PRODUCT, OR THAT HE OR SHE IS QUALIFIED TO REPLACE ANY PARTS OF THE PRODUCT. THE MANUFACTURER AND/OR DISTRIBUTOR EXPRESSLY STATES THAT ALL REPAIRS AND PARTS REPLACEMENTS SHOULD BE PERFORMED BY CERTIFIED AND LICENSED TECHNICIANS, AND NOT BY THE BUYER. THE BUYER ASSUMES ALL RISK AND LIABILITY ARISING OUT OF HIS OR HER REPAIRS TO THE ORIGINAL PRODUCT OR REPLACEMENT PARTS THERETO, OR ARISING OUT OF HIS OR HER INSTALLATION OF REPLACEMENT PARTS THERETO.

Product's Serial Number: _____

Note: If product does not have a serial number, record the month and year of purchase instead.

Note: Some parts are listed and shown for illustration purposes only, and are not available individually as replacement parts.

FRONT WHEEL CLAMP

INSTALLATION DRAWING

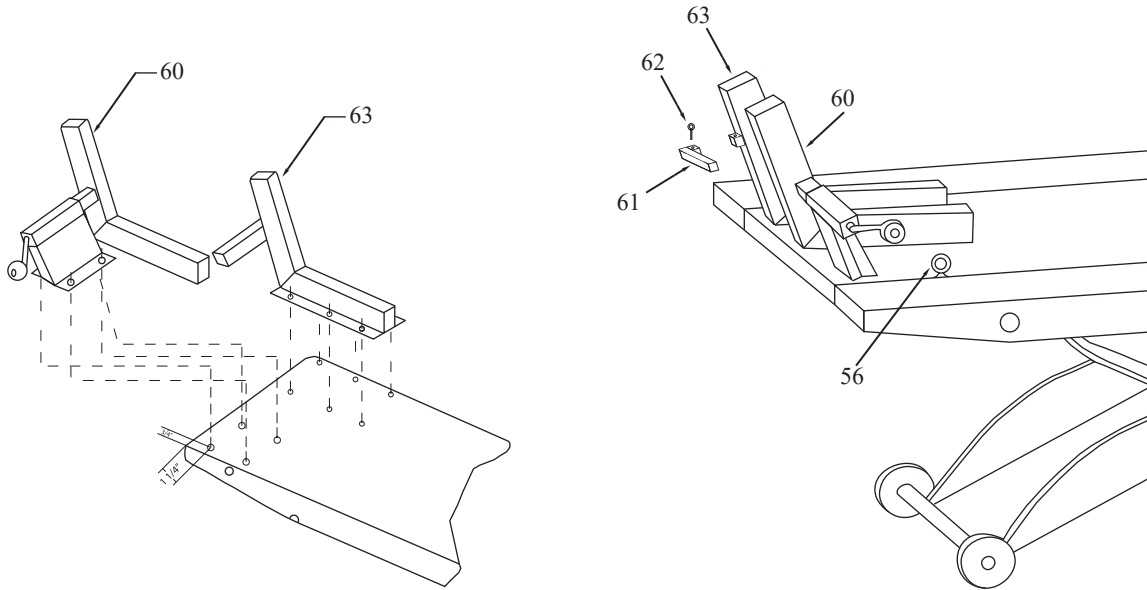

FRONT EXTENSION

INSTALLATION DRAWING

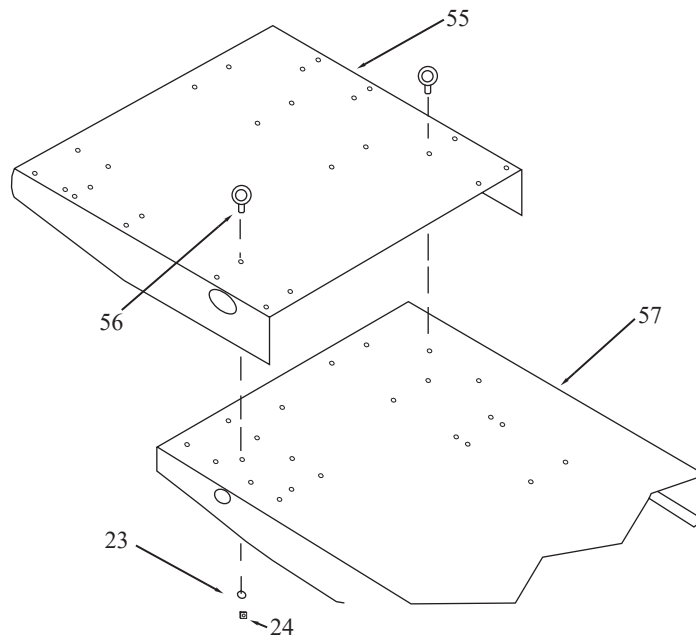

SIDE EXTENSIONS

INSTALLATION DRAWING (XLT ONLY)

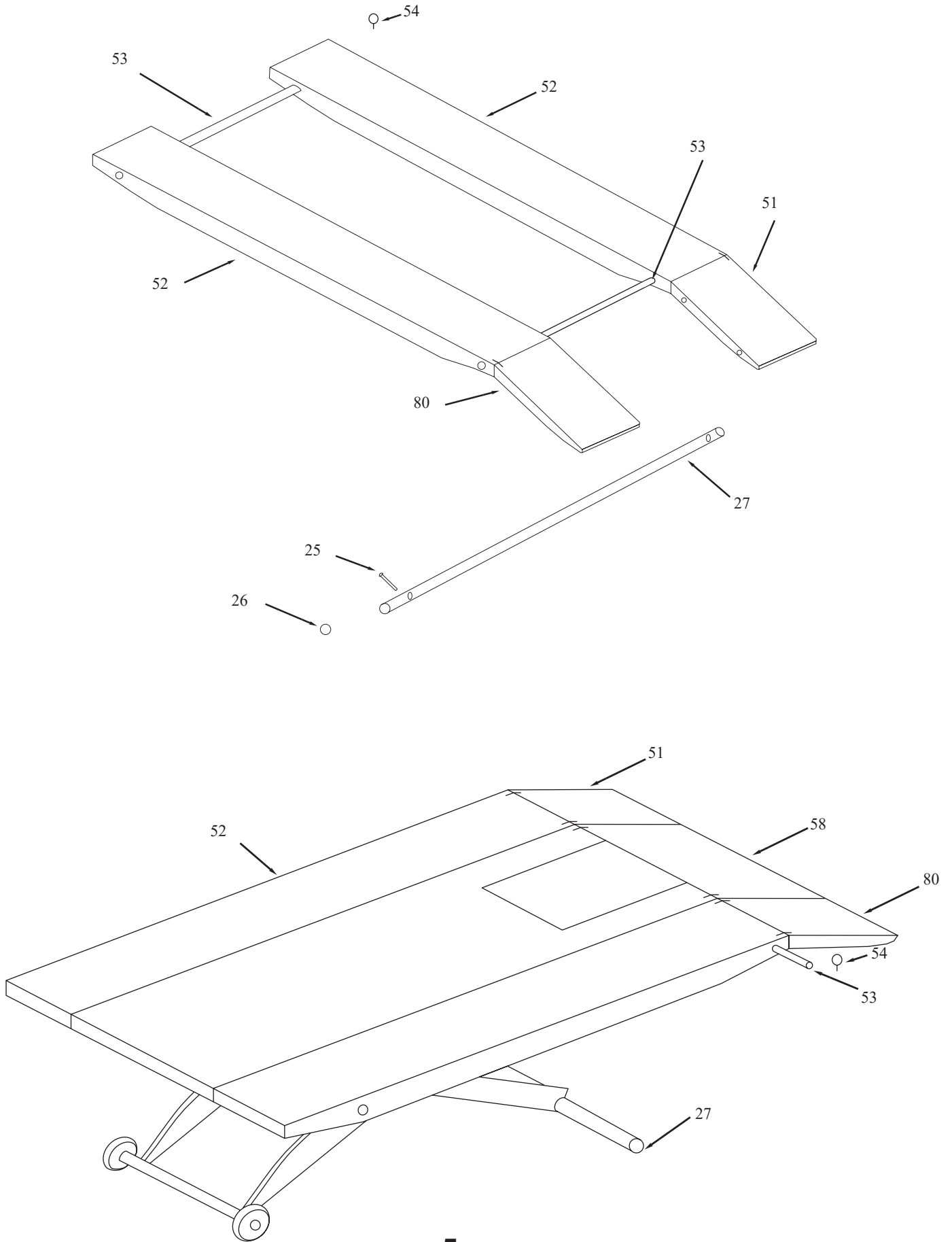

PARTS LIST (FIG. 1)

PLEASE MAKE SURE TO CONFIRM THAT ALL PARTS ARE INCLUDED.

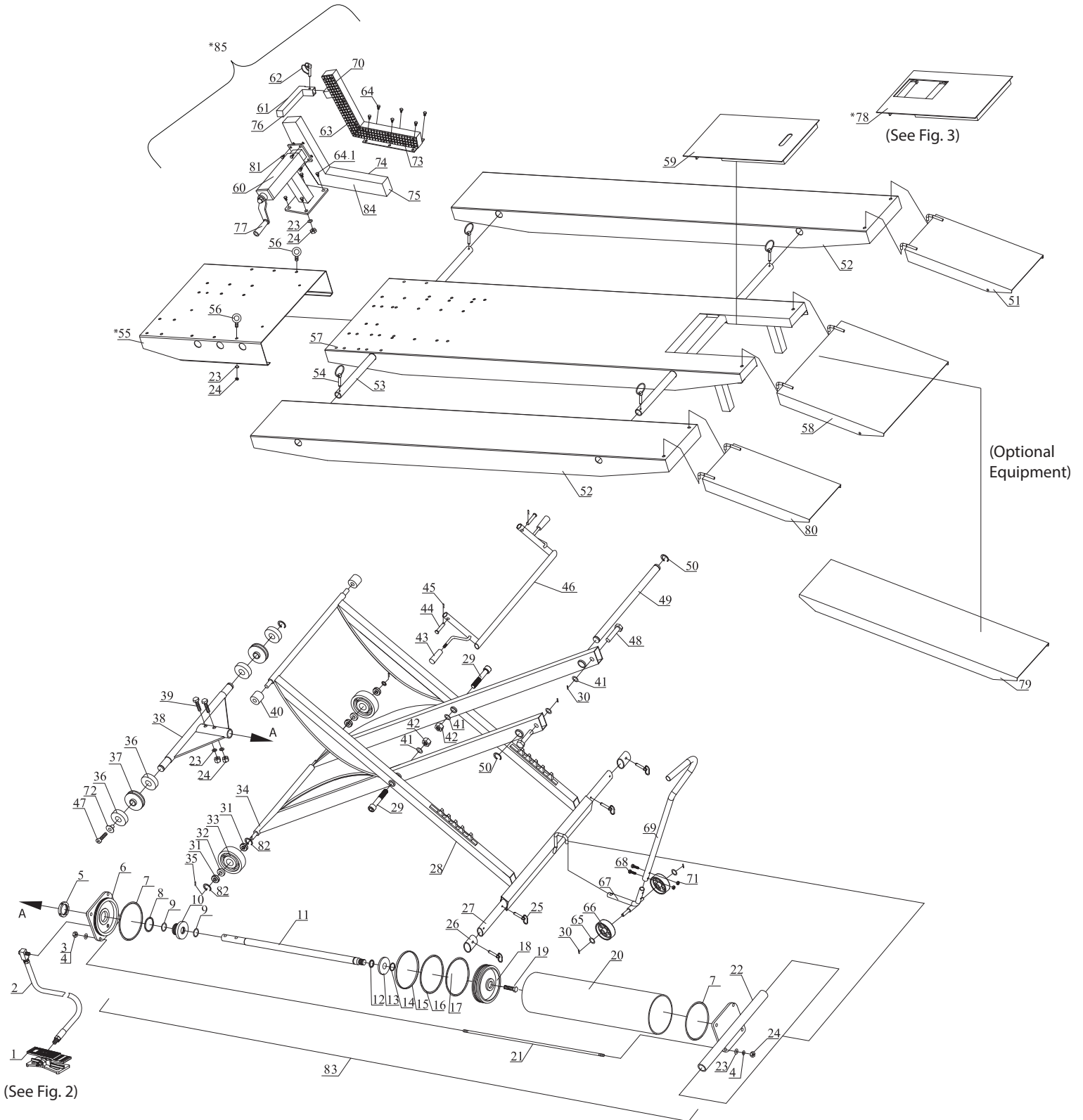

PARTS LIST (FIG. 1) - CONTINUED

NO.	DESCRIPTION	QTY	NO	DESCRIPTION	QTY
1	FOOT OPERATED AIR VALVE - Fig. 2	1	44	PIN	2
2	AIR HOSE	1	45	R-PIN	2
3	SCREW CAP M10	4	46	SAFETY BAR (COLOR)	1
4	WASHER Φ 10	8	47	MACHINE BOLT	2
5	NUT	1	48	PIN	2
6	FRONT COVER	1	49	CYLINDER PIVOT SHAFT	1
7	NYLON O-RING	2	50	RETAINING RING	2
8	O-RING	1	51	RIGHT EXTENSION RAMP - XLT ONLY	1
9	O-RING	2	52	SIDE EXTENSION - XLT ONLY	2
10	SHAFT BUSHING	1	53	SUPPORT PIPE - XLT ONLY	2
11	PISTON ROD	1	54	QUICK PIN - XLT ONLY	4
12	RETAINING RING	1	55	*FRONT EXTENSION	1
13	PRESS RING	1	56	EYE BOLT	2
14	O-RING	1	57	DECK PLATE	1
15	PLASTIC O-RING	1	58	MAIN RAMP	1
16	O-RING	1	59	STANDARD DROPOUT PLATE (COLOR)	1
17	O-RING	1	60	CRANK ASSEMBLY (COLOR)	1
18	PISTON	1	61	TIRE STOP (COLOR)	1
19	BOLT	1	62	WHEEL STOP PIN	1
20	CYLINDER CASING	1	63	FIXED CLAMP (COLOR)	1
21	STAY BOLT	4	64	BOLT 18mm	6
22	CYLINDER END PLATE	1	64.1	BOLT 25mm	4
23	WASHER Φ 10	12	65	WASHER PRESS RING	2
24	NUT M10	12	66	DOLLY WHEEL	2
25	STEEL BALL PIN - XLT ONLY	4	67	DOLLY BASE (COLOR)	1
26	STABILIZATION PIPE CAP - XLT ONLY	2	68	BOLT	2
27	STABILIZATION BAR - XLT ONLY	1	69	DOLLY HANDLE (COLOR)	1
28	LIFTING ARM - OUTSIDE (COLOR)	1	70	FLAT HEAD MACHINE SCREW	24
29	INNER HEXAGON SCREW	2	71	NUT	2
30	COTTER	4	72	PRESS RING	2
31	BEARING	4	73	RUBBER VISE PAD - RIGHT	1
32	PRESS RING	2	74	RUBBER VISE PAD - LEFT	1
33	WHEEL (COLOR)	2	75	PLASTIC VISE END CAP - BLK	4
34	LIFTING ARM - INSIDE (COLOR)	1	76	PLASTIC WHEEL STOP END CAP - BLK	2
35	RETAINING RING	2	77	VISE HANDLE - PLASTIC	1
36	BEARING	4	78	*ROLLER DROPOUT - Fig. 3 (COLOR)	1
37	PRESS RING	2	79	LONG RAMP	1
38	CONNECTION (COLOR)	1	80	LEFT EXTENSION RAMP - XLT ONLY	1
39	BOLT M10*45	2	81	BOLT (VISE ATTACHMENT)	4
40	ROLLER	2	82	RETAINING RING	4
41	WASHER Φ 16	4	83	COMPLETE CYLINDER ASSEMBLY	1
42	LOCK NUT M16	2	84	MOVEABLE CLAMP (COLOR)	1
43	SAFETY BAR HANDLE	2	85	*COMPLETE VISE ASSEMBLY (COLOR)	1

*OPTIONAL EQUIPMENT

FOOT VALVE PARTS DETAIL (FIG. 2)

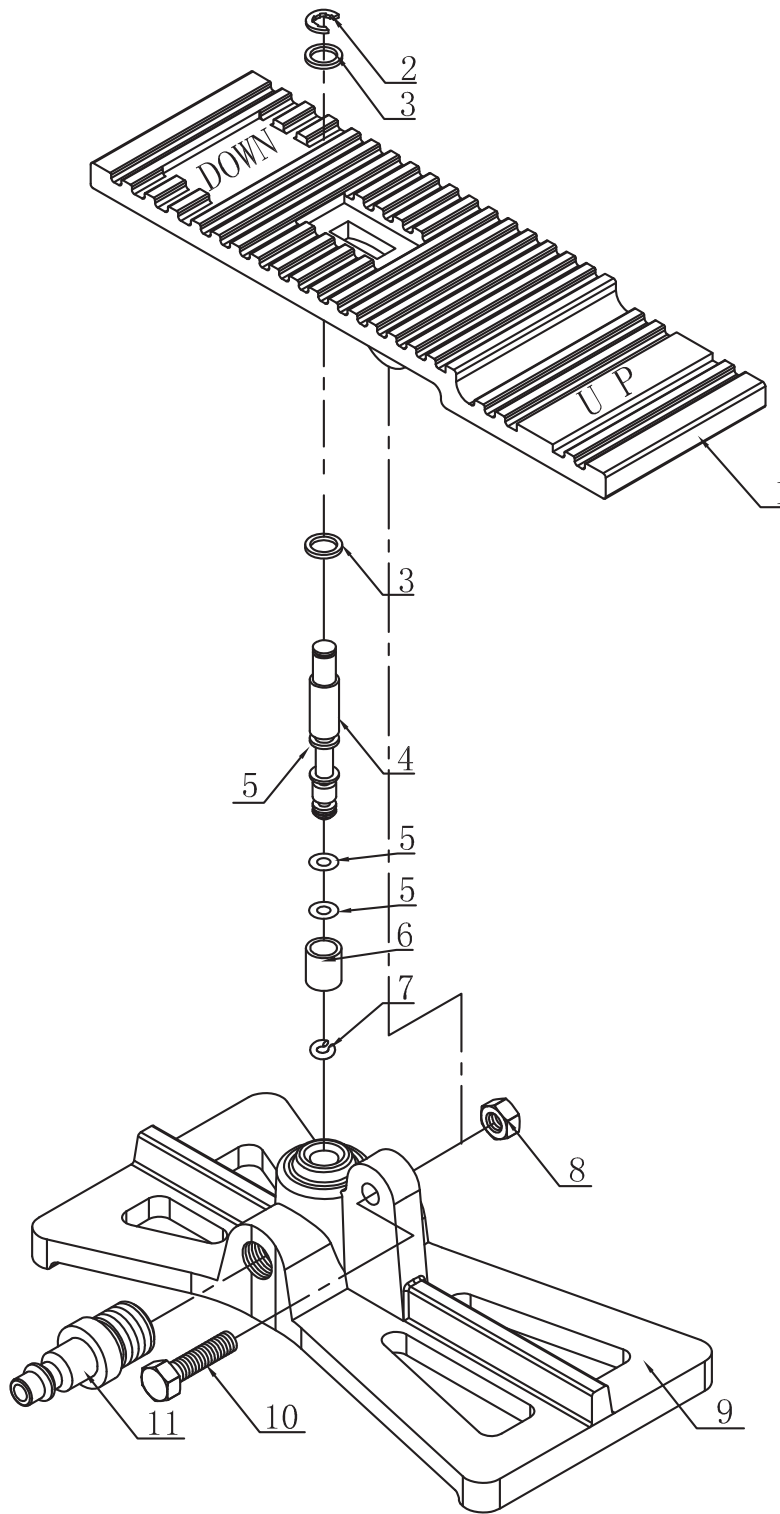

NO.	DESCRIPTION	QTY	NO	DESCRIPTION	QTY
1	FOOT PEDAL	1	7	SNAP RING	1
2	RETAINING RING	1	8	LOCK NUT	1
3	WASHER	2	9	BASE	1
4	PLUNGER VALVE	1	10	HEXAGON BOLT	1
5	O-RING	3	11	AIR FITTING	1
6	NYLON BUSHING	1			

ROLLER DROP-OUT PARTS DETAIL (FIG. 3)

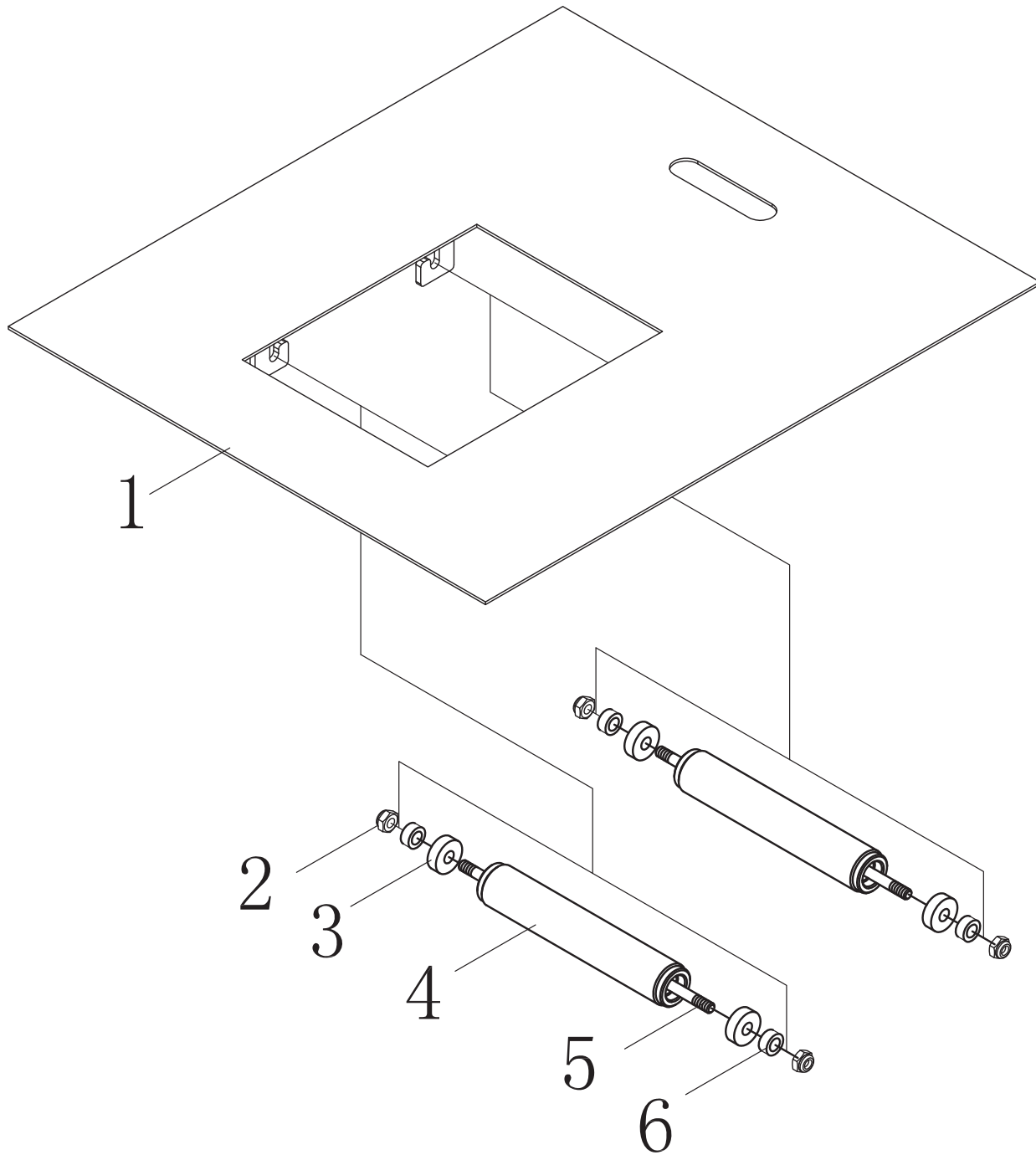

NO.	DESCRIPTION	QTY
1	DROPOUT PLATE (COLOR)	1
2	RETAINING NUT M8	4
3	BEARING	4
4	ROLLER	2
5	PIN	2
6	BUSHING	4

WARRANTY REGISTRATION

In order to utilize the warranty on this Titan Lifts product, you must register your product with us. The simplest way to do this is to visit [TITANLIFTS.COM/WARRANTIES](https://www.titanlifts.com/warranties) and submit your information online. If you prefer to send your information through the mail, please fill out the form below and send this page to us at :

**Titan Lifts
PO Box 7069
Greenwood, IN 46142**

EQUIPMENT MODEL: _____ SERIAL NUMBER: _____
TYPE OF POWER UNIT: _____ SERIAL NUMBER: _____
DATE OF PURCHASE: _____
PLACE PURCHASED: _____
NAME: _____
STREET: _____
CITY, STATE, ZIP: _____
PHONE: _____
EMAIL: _____

OPT OUT OF PROMOTIONS



In order to receive your warranty, return this card or visit [TITANLIFTS.COM/WARRANTIES](https://www.titanlifts.com/warranties) within 30 days.



LIMITED WARRANTY

The **Titan 2 Post lifts and 4 Post lifts** are backed by a standard **1 year** replacement parts warranty and a **5 year** structural warranty from the date of purchase, to the original purchaser only. The **1 year** replacement parts warranty covers power units, hydraulic cylinders, and all other assembly components such as, but not limited to: turn plates, slip plates, cables, chains, valves, switches etc. This does not cover normal wear items such as but not limited to rubber lifting pads and nylon slide blocks. Titan **HD2P-9000ACE-D** and **HD2P-9000AFE 2 Post lifts** are backed by a **2 year** replacement parts warranty and a **5 year** structural warranty from the date of purchase, to the original purchaser only. The **2 year** replacement parts warranty covers power units, hydraulic cylinders, and all other assembly components such as, but not limited to: turn plates, slip plates, cables, chains, valves, switches etc. This does not cover normal wear items such as but not limited to rubber lifting pads and nylon slide blocks.

Titan Mid Rise Scissor lifts are backed by a standard **1 year** replacement parts warranty and a **5 year** structural warranty from the date of purchase, to the original purchaser only. The **1 year** replacement parts warranty covers power units, hydraulic cylinders, and all other assembly components such as, but not limited to: turn plates, slip plates, cables, chains, valves, switches etc. This does not cover normal wear items such as but not limited to rubber lifting pads and nylon slide blocks.

Titan Standard Duty and Heavy Duty motorcycle lifts are backed by a standard **1 year** replacement parts warranty from the date of purchase, to the original purchaser only. The **1 year** replacement parts warranty covers power units, hydraulic cylinders, pneumatic cylinders, and all other assembly components such as, but not limited to: cables, caster wheels, valves, switches, wheel vises etc. This does not cover normal wear items such as but not limited to rubber wheel vise pads.

Titan Bulldog Moto Cradle Wheel Chock is warrantied for replacement parts, only to the original purchaser, for a period of **2 years** from the date of purchase.

XL Tool by Titan Wheel Service Machines and Helper Arm Assemblies are backed by a standard **1 year** replacement parts warranty from the date of purchase, to the original purchaser only. The **1 year** replacement parts warranty covers internal boards, motors, pneumatic cylinders, and all other assembly components such as, but not limited to: cabinet, switches, valves, fittings etc. This does not cover normal wear items such as but not limited to: rubber pads, jaw protectors, air hoses, quick nut assemblies.

Titan shop equipment products and accessories are warrantied for replacement parts only to the original purchaser for a period of **90 days** from the date of purchase. This **90 day** replacement parts warranty covers products such as but not limited to: EZ -Mover Jacks, Mini Jacks, tie down products, wheel service accessories, Bulldog Moto Cradle Wheel Chock accessories, dollies, stands, Light Duty Motorcycle Lifts, etc.

For **all** warranty considerations, Titan Marketing, LLC will supply replacement parts only during the warranty period. The original purchaser is responsible for all shipping, handling, and any labor charges incurred. All defective parts must be returned to Titan for inspection and examination. Any parts that are found to be defective will be replaced or repaired to proper working order. Other items not listed above may be considered general wear parts and therefore, will not be covered under warranty. These warranties **do not** extend to **defects** caused by ordinary wear, abuse, misuse, shipping damage, improper installation, voltage or lack of required maintenance. Titan Marketing, LLC is **not** to be held responsible for any **failure** that results from an accident, purchaser/operator abuse, neglect, or failure to operate products in accordance with instructions provided in the owner's manual(s) supplied. Damage caused by rain, excessive humidity, corrosive environments or other contaminants are not covered under warranty. **THESE WARRANTIES DO NOT EXTEND TO ANY COSMETIC DEFECT NOT INTERFERING WITH EQUIPMENT FUNCTIONALITY OR ANY INCIDENTAL, INDIRECT, OR CONSEQUENTIAL LOSS, DAMAGE, OR EXPENSE THAT MAY RESULT FROM ANY DEFECT, FAILURE OR MALFUNCTION OF A TITAN MARKETING LLC PRODUCT OR THE BREACH OR DELAY IN PERFORMANCE OF THE WARRANTY.**

P.O. Box 7069 • Greenwood, IN 46142 • Ph. 888-908-4826 • Fx. 317-215-2770 • www.titanlifts.com

 **WARNING** 

The warnings, precautions and instructions in this manual cannot cover all possible conditions and situations that may occur. The operator must understand that the operator must supply common sense and examine caution factors when using this product to determine safety in all circumstances being used.



TITAN MARKETING, LLC

PO Box 7069 Greenwood, IN 46142
1.888.908-4826 FAX (317) 215.2770
www.titanlifts.com

**Patent No.: US 8,104,588 B2
CA 2,729,670**

Date: 12/15/23